

# **MINISTRY OF ENERGY AND MINERAL DEVELOPMENT**

## **A Comparison of Wood-Burning Cookstoves for Uganda: Testing and Development**

**GTZ**

Emma George

June 2002

### **Note to the reader**

If your first language is not English; or if you are not sure what “efficiency” is, you should read “Woodstoves for Uganda” from the Ministry of Energy and Mineral Development and GTZ by Emma George. It is about the same tests.

Any comments to the author at [emma@george.as](mailto:emma@george.as) are much appreciated.

### **Acknowledgements**

Thanks to Dean Still at Aprovecho research centre, USA, for expert advice, also to Phillippe Simonis at GTZ for his support and to Prossy Bidda for such reliable help and stove operation.

# Contents:

EXECUTIVE SUMMARY .....	1
1 INTRODUCTION.....	5
2 DESIGN AND CONSTRUCTION.....	7
2.1 Lorena .....	7
2.2 Dembe (Unicef) .....	10
2.3 Shielded Three-Stone Fire .....	13
2.4 Metal Woodstove.....	14
2.5 Three-Stone Fire .....	15
3 BACKGROUND TO METHODOLOGY .....	16
3.1 Relevant Measurements .....	16
3.1.1 High Power Measurements .....	16
3.1.2 Low Power Considerations .....	16
3.1.3 Meal Cooking.....	18
3.2 Tests Performed .....	18
3.3 Errors and Uncertainties .....	19
4 TESTS .....	20
4.1 High Power Boiling .....	20
4.1.1 Method .....	20
4.1.2 Results and Discussion .....	20
4.2 Low Power Boiling.....	22
4.2.1 Method .....	22
4.2.2 Results and Discussion .....	23
4.3 Meal Cooking.....	25
4.3.1 Method .....	25
4.3.2 Results and Discussion .....	26
4.4 Summary of results .....	28
5 IMPROVEMENT OF DESIGNS.....	29
5.1 Basic Principles of the Burning and Heating Process.....	29
5.1.1 Combustion .....	29
5.1.2 Heat Transfer .....	30
5.2 Smoke Removal .....	32
5.3 User Needs and Perceptions.....	33
5.4 Production and Distribution.....	36
5.5 Stoves Selected .....	37
6 TESTING THE IMPROVED STOVES.....	38
6.1 High power.....	38
6.2 Low Power .....	40
6.3 Meal Cooking.....	42
6.4 Summary of Results .....	44
7 BENEFIT ASSESSMENT .....	45
8 CONCLUSIONS .....	48
8.1 Suggestions for Next Steps .....	49
REFERENCES .....	51

# Executive Summary

## Abstract

*Five existing woodstove types (Lorena, Dembe, shielded 3-stone fire, open 3-stone fire and a metal stove) are described. These are tested to find; maximum power output, efficiency at high power, fuel consumption for a 90 minute simmering task and for a Ugandan meal-cooking task. It is determined that the 3-stone fire gives a 16% efficiency at high power in sheltered conditions, and the metal stove gives a substantial improvement on this, 22%. However, the Lorena and Dembe stoves give a much lower figure, at 7-8%. The metal stove also has lowest fuel consumption at simmering power, but it is found that the use of a lid is more significant to efficiency than stove type when simmering. These figures are reflected in a meal-cooking test in which the metal stove is fastest and uses least fuel, and the Dembe is by far the slowest and uses most fuel, (together with the Lorena). A shielded 3-stone fire offers some savings compared to a traditional fire. Basic principles of combustion and heat transfer are discussed and used to justify the construction and testing of four further stoves; a rocket stove (giving 23% efficiency but a low maximum power), a metal stove with a chimney (18%), an improved shielded 3-stone fire (24%) and the Estufa Justa or "improved Lorena" (21%). It is therefore stressed that the Lorena and Dembe stoves are not fuel saving, and since other stoves can offer the same additional benefits, such as smoke removal, they should be abandoned in favour of more efficient designs.*

## Background

It is commonly believed among Ugandans and Ugandan NGO's that the Lorena woodstove saves around 50% fuel compared to a 3-stone fire. This is generally rejected by researchers, such as those at Aprovecho research centre, which was involved in the original Lorena design process. One Ugandan report (Manyindo, 2001), finds there is approximately equal consumption for both brick Lorena and three-stone fires, but the report lacks some detail, error analysis and repetition of tests, and it covers only these two stove types. Other reports (Shanahan, Joseph et al 1982) find the Lorena efficiency is below the average 3-stone fire efficiency determined. Prasad and Verhaart 1983 puts the efficiency of such heavy earthen stoves at around 6%, three-stone efficiency estimates are mostly above 10%. It is felt that a test conducted in Uganda, using local stove constructors, cooking practices etc. will identify efficient stoves as well as inefficient ones. It is also hoped that the results will be immediately relevant to those promoting and using the stoves here.

## **Problem statement**

This report, associated with the Ministry of Energy and the GTZ Energy Advisory Project, attempts to answer the following questions:

- How effective are the five stove types in using fuel wood efficiently during various stages of the cooking process, and when used to cook a common Ugandan meal?
- How important is the use of a lid to the efficiency of the cooking process?
- What improvements can be made to the stoves?

## **Conclusion and Recommendations**

- Use of a lid is more significant to fuel consumption than stove type employed. Organisations should educate (or continue to educate) those disseminating stoves on this issue and give it priority.
- Lorena and Dembe stoves are substantially less efficient at high power than a three-stone fire (see Figure1-1). They also have a higher fuel consumption for a 90 minute simmering test at low power, and for cooking a traditional Ugandan meal (Figure1-2). They should not be promoted on the basis of fuel saving. The good reputation of the Lorena is due to a self-perpetuating myth.
- The Dembe stove has fundamental design flaws, which prevent effective heat transfer. Airflow through the stove allows much heat to escape through the chimney. Consequently, the maximum power delivered to the pot is low compared to other stoves. This results in extended cooking times, leading to increased fuel consumption.
- A simple and cheap metal cylinder stove can produce significant fuel savings compared to a 3-stone fire. The metal stove would seem to be a possible candidate for promotion in Uganda, providing it is culturally acceptable. It can be produced cheaply from scrap metal, and is light so transportation should be possible. However it must fit the pot used, so, if tailor-made stoves are impractical, a range of sizes must be available, to fit common pot sizes. The stove's disadvantage is that smoke is not removed. A chimney can be added to the stove side, resulting in a 4% (abs) drop in efficiency. Many will feel this is an acceptable price for the health benefits received.
- A number of design flaws can be identified in the inefficient stoves, and corrected in the selection of a new stove. Desirable features for improved efficiency include; insulation around the firebox and air channels, an internal chimney to allow hot flue gasses to rise inside the stove, a rocket elbow to heat incoming air and an airflow in the stove which directs hot flue gasses into close contact with a large surface area of the pot.
- Undesirable features include a high mass firebox constructed from non-insulative materials, such as the packed earth in the Lorena and Dembe.
- These principles are incorporated into the rocket stove, the improved shielded 3-stone fire and Estufa Justa stove. They give high efficiencies, as well as removing or reducing smoke. These, together with well-presented information and lid use promotion could give a substantial fuel saving and a significant time saving for cooks in Uganda. More work should be done to

increase the maximum power of the rocket stove, and to adjust the power ratio for the two Estufa Justa pots. Further work should be based on user feedback and promoters experience.

Figure1-1 Graph to Show Efficiency of Stoves Tested

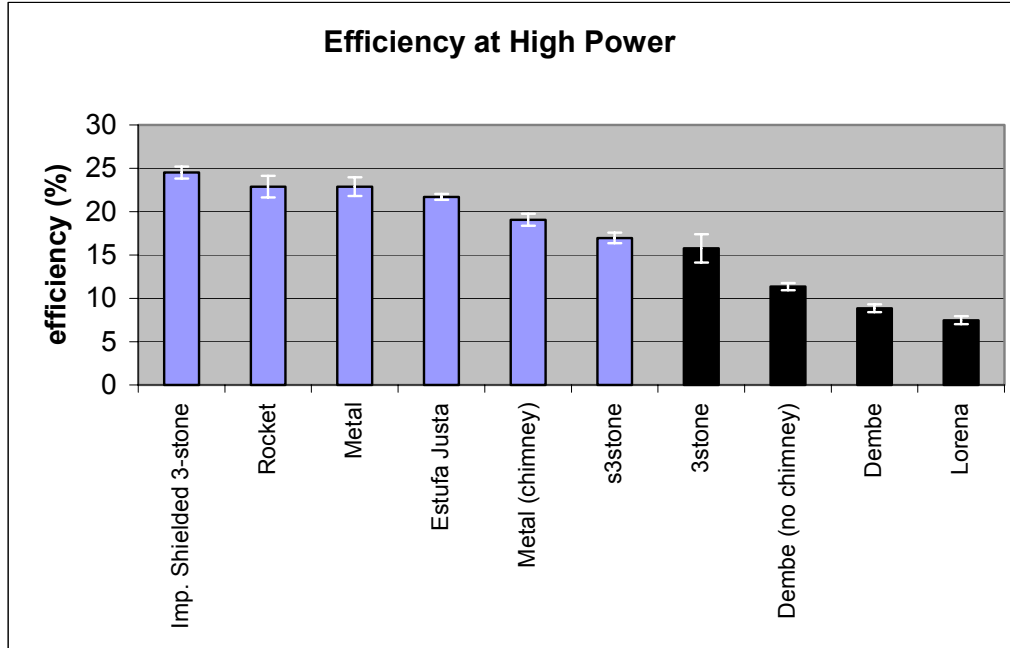

Bars shaded black indicate stoves readily available in Uganda

Figure1-2 Percentage savings for meal cooking

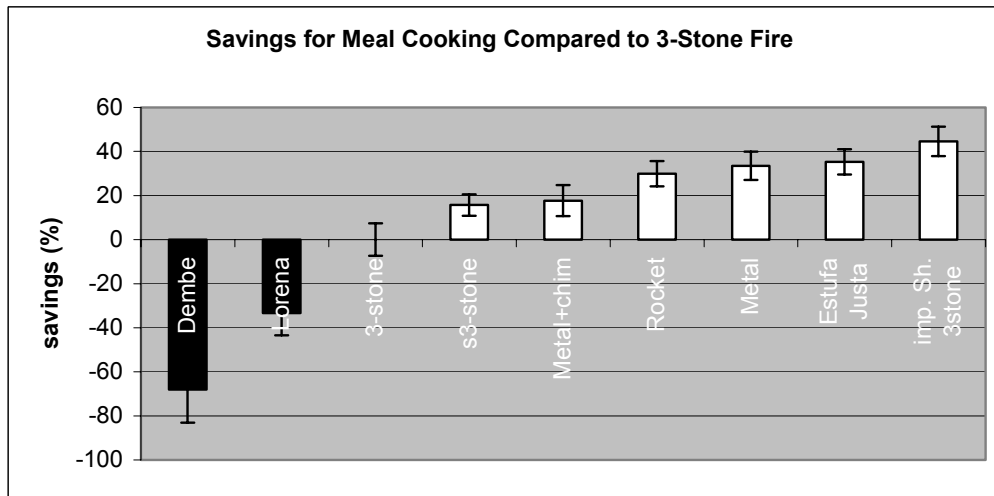

The improved stoves should be distributed to Ugandan users, initially through NGO's to obtain feedback on their suitability. Possible changes should be made, and dissemination widened. The stoves should be continually improved according to feedback from users. However, the basic design principles must be remembered, and stoves should **always** be tested before adoption.



# 1 Introduction

## The motivation behind improved woodstoves

It is well known that 95% of Uganda's energy is obtained directly from wood fuel. It is also known that **deforestation and erosion** is a major environmental problem in Uganda. While it is not universally accepted that using wood fuel is the main cause of deforestation, it is certainly one cause, and it is believed that efficient fuel use can reduce the problem significantly. This is especially true in high population density areas, where wood fuel harvesting is in fact the main cause of deforestation (Forest Department of Uganda 1993). It is predicted that sustainable wood fuel production will equal demand by 2014, but in the meantime acres of valuable ecological resources are going up in smoke, currently at a rate of 240 million tonnes per year (NEMA 2001). One aim of improved fuel-saving woodstove development and promotion is to reduce this figure as fast as possible.

Another vital aim is to improve the **lifestyle of wood fuel users**. For Ugandan women, who commonly spend up to half their waking hours in the kitchen, smoke inhalation often causes **respiratory problems**. Acute Respiratory Infection caused by wood smoke and other substances is responsible for 8.2% of infant deaths in Uganda (NEMA 2001). In addition, harmful gases in wood smoke such as sulphur dioxide and carbon monoxide cause such conditions as mental impairment and cardiovascular disease. Thus, a chimney to remove harmful emissions is of immense benefit.

Each day thousands of **work hours** are spent collecting wood, usually by women and children. By using less wood, some of this time could be spent more usefully. In towns, where wood is purchased, **saved money** could be spent, improving material living standards.

An increased trade in woodstoves could **provide income** for workers producing, selling and repairing them. In Kenya and Ethiopia stove programmes have been shown to play a positive role in poverty alleviation, while urban improved stove programmes in Uganda have not enjoyed the same level of success (DFID 2000).

While Uganda's **CO<sub>2</sub> emissions** are small compared to many countries in the North, an added benefit of reduced fuel use would be a smaller contribution to the ever-rising greenhouse gas concentration in the atmosphere.

## Evaluating Stoves

There are several factors to take account of when selecting a woodstove. These include efficiency, cost, smoke removal, convenience and cultural factors. This



report focuses mainly on the efficiency of the stove, but since all aspects of the stove must be acceptable if promotion is to be successful, other factors are taken into consideration where appropriate. Since factors such as user requirements vary considerably from area to area, this report is intended to provide only part of the necessary information for stove selection.

Many “fuel-efficient” stove types have been designed and promoted around the world over the past 30 years. The traditional **3-stone fire** is still the most usual way to cook with wood fuel in Uganda. Estimates of its **efficiency**<sup>1</sup> vary widely, depending on conditions of use. This creates difficulties in evaluating savings figures for other stoves in comparison. Table 1.1 provides efficiency percentage figures quoted in Gill (1985) for the 3-stone fire based on experimental results:

*Table 1.1 Efficiency results for three stone fire from the literature*

<b>Reference</b>	<b>Efficiency (percent)</b>
Brattle, 1979	11.2 – 25.5
Visser et al, 1979	13 – 26
Joseph and Sharsahan, 1981	14 – 30
Visser and Verhart, 1980	11 – 23
Ascough, 1980	3.5
Bussman et al, 1983	22 – 36
Quedrargo et al, 1983	4.9 – 17.4

Source: Gill (1985)

These tests aim to establish efficiency and fuel consumption figures for the 3-stone fire to perform various tasks in sheltered conditions, in order to allow **comparison with other stoves** in the same conditions.

The Lorena and Dembe (also known as Unicef) stoves are relatively common, the shielded 3-stone fire has also been promoted to some extent. The metal woodstove is rare here, but is available and popular in nearby Kenya.

**The Lorena** was developed in South America in the 1970’s, with assistance from scientists from Aprovecho research centre in the U.S. It still has many supporters. It seems to be commonly accepted in Uganda that the Lorena offers a **50% fuel saving** compared to an open 3-stone fire. Many stove promoters state that stove users report this figure.

---

<sup>1</sup> Percentage of energy present in the fuel wood which is transferred to the water (or food) in the pot.

However, a recent Ugandan report (Mayindo 2001) finds that fuel consumption is approximately equal for the two<sup>2</sup> although a significant time saving was realised for the Lorena. This is presumably largely due to the option to heat two pots simultaneously.

Indeed, for 20 years, many have been claiming that the Lorena does not save fuel compared to the open fire, and even that it is **less efficient** (Shanahan 1982). Efficiency results for high mass stoves range from 6% (Prasad and Verhaart 1983) to 12% (Tuta 1982) Despite this, organisations continue to promote it, and users to report savings. This report aims to resolve the discrepancy, and to determine which of the five stoves to be tested is most efficient. The results, and information from other sources will be used to design or select the most efficient and appropriate alternatives.

## Outline of report

Chapter 2 gives the details of the **stoves** to be tested, dimensions used etc. It is not a construction manual, but some construction details are included to allow the reader to understand exactly *what* is being tested. Chapter 3 explains the **reasoning** behind the choice of testing methods, introduces the three tests chosen and lists the quantities they are designed to measure. Chapter 4 describes the **experimental procedure** used, followed by the **results** obtained and some discussion. **Error treatment** is discussed at the beginning of this chapter. Chapter 5 briefly explains the **principles** taken into account when selecting a **new stove** for efficiency and shows four further stove types. Smoke removal and user needs are also taken into account in the design selection. The test results for these are presented in Chapter 6. Chapter 7 Summarises the key **benefits offered** by each stove. Chapter 8 presents the **conclusions**.

---

<sup>2</sup> According to the results section - although the conclusion claims a slight advantage for the Lorena(!)

## 2 Design and Construction

Tests were conducted on five stove types:

- Lorena
- Dembe (Unicef)
- Metal woodstove
- Shielded 3-stone fire
- Open 3-stone fire

The mud stoves were constructed by staff members from the Ugandan NGO, IRDI<sup>3</sup> Kampala according to usual practices. Common variations from the stoves used are mentioned. Stoves were constructed under a shelter with concrete walls up to about 1 m high. The sides above this height were open to the outdoors. The stoves were protected from sun, rain and wind. The Lorena, shielded 3-stone fire and metal stove are constructed to fit the pots used. The same 26.5 cm diameter pot was used for all stoves, with an additional 23 cm pot for the Lorena.

All dimensions for the stoves have an error of  $\pm 1$ cm since edges are often not sharply defined and small irregularities are common.

### 2.1 Lorena

The Lorena stove was constructed entirely from a sand : anthill-soil mixture. No bricks were used. The reddish soil found in anthills common in Uganda has a high plasticity and is conveniently free from stones. However, the properties of this soil vary significantly. In our case the anthill soil (AHS) was of poor quality, so a 2:1 ratio AHS : sand was used. The AHS had been taken from an anthill some time previously, and had stood for some time outdoors; it was therefore necessary to sieve it through a  $\approx 4$ mm mesh to remove lumps. The sand used was coarse (lake) sand, this was sieved in the same way to remove stones.

The sand: AHS mixture was mixed thoroughly with a shovel. Water was added gradually as the mixture was blended using the feet (thus pressure is applied via body weight). The right consistency is achieved when a roll of the mixture a few cm thick will bend a little before breaking.

---

<sup>3</sup> Integrated Rural Development Initiatives

The dimensions of the stove are determined by the sizes of pots to be used. The two pots used here measured 23 and 26.5 cm in diameter. The top of the stove is measured out with a palm-width separating the pots and the chimney hole, 12cm diameter.

Figure 2-1 Plan view for Lorena

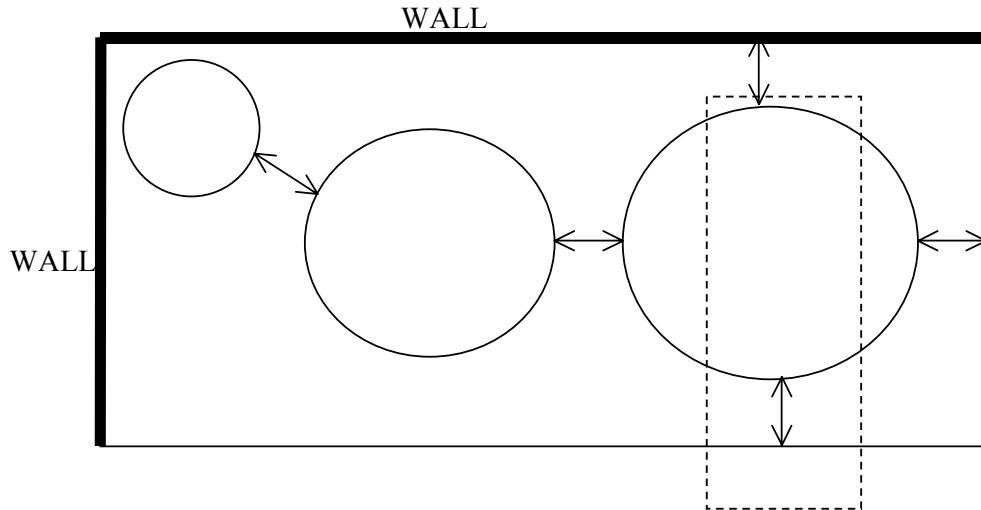

All measurements marked  $\longleftrightarrow$  are around 7 cm, or one hand-width

Such a rectangle is marked on the ground the stove will stand on, walls of the building forming two sides of the shape, which is covered with a layer of mixture a few cm deep. This is depicted in Figure 2-1.

A banana stem (diameter 13 cm) will form a mould for the firebox opening. It is laid onto this base as indicated by broken lines in Figure 2-1.

The entire volume of the stove (up to a height of 30 cm) is filled with AHS : sand mixture by throwing handfuls downwards with some force. The sides and top are smoothed, and holes are cut to exactly fit the pans to a depth of 5 cm.

The banana stem is removed and a hole is cut in the centre of the pot rest above down to the firebox, leaving a rim of 3 cm for the pot to rest on. Channels are cut out of the stove volume to link the firebox, pot rests and chimney as shown in Figure 2-2. The channel leading from the firebox to the smaller pot narrows as it reaches the pot base. A baffle 5 cm wide is important to direct hot air to the pot base.

A small platform is created on the ground in front of the firebox.

Rolls of mixture are laid in rings around the chimney exit hole in layers to create a cylinder for the chimney to a height of around 15 cm. The chimney cannot be completed until the stove has dried for 2-3 weeks.

The stove is covered with banana leaves to protect from sun and to prevent fast drying which leads to cracking. Each day for the next three days, the pots are wetted and rotated within the pot rest holes to ensure that the holes do not shrink during drying.

Figure 2-2 Side cross section of the Lorena stove

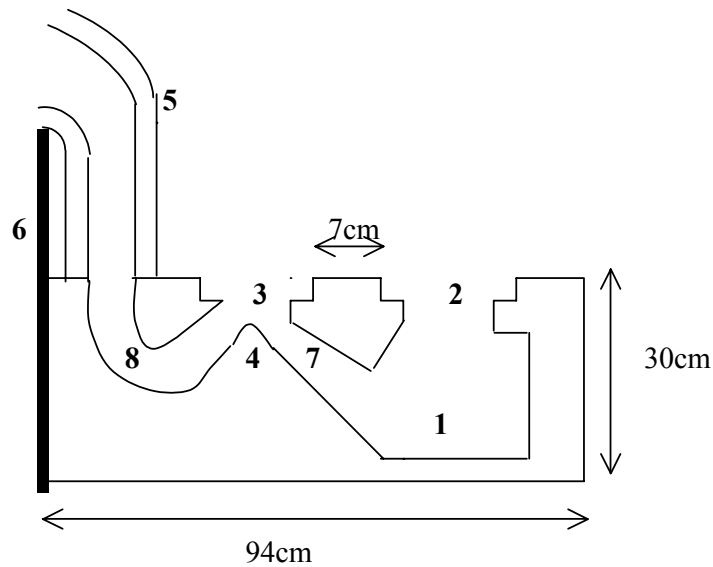

- 1 Firebox; volume created by removed banana stem. Height to pot base 21cm, width 20cm, depth 22cm
- 2 Pot rest for larger pot. Outer diameter 27cm (to fit pot) inner diameter 17cm depth 6cm
- 3 Pot rest for smaller pot Outer diameter 24cm (to fit pot), inner diameter 14cm depth 5cm
- 4 Buffer to direct smoke to base of small pot, 1cm wide, 4cm from pot base
- 5 Chimney 13cm inner diameter, height to bend 65cm, total length 89cm
- 6 Outer wall of shelter (concrete)
- 7 Air channel, narrows from 14cm to 6cm diameter. Height difference between firebox base (1) and buffer top (4) 24cm
- 8 Air channel to chimney, diameter 10cm. Height drop in channel after buffer 15cm

### Common Variations

The design of the Lorena varies somewhat, even within the same organisation, often to suit the user's needs.

- A brick layer is commonly used as a base, and to elevate the stove to a comfortable height for cooking

- The dimensions of the stove depend on the pot size; the pots used here should be typical for a young family of five.
- Three-pot Lorenas are also used
- Chimney size and shape varies considerably, in some cases no chimney is used.
- Higher plasticity AHS is also common and can be used in a ratio of up to 3:1 sand:AHS
- Fine (river) sand is used where available instead of the coarse sand used here. This affects the durability of the stove

## 2.2 Dembe (Unicef)

The Dembe<sup>4</sup> stove was constructed using the same 2:1 AHS:sand mixture as the Lorena. It is formed using a wooden mould (see Figure 2-3). The mould is packed tight with rolls of mixture and “coach grass”. Two forms from the same mould are placed on top of one another, to create the stove, the lower half having some parts cut away to form air channels.

### 1. *Forming the “rolls”:*

A handful of coach grass is spread on the ground in a line 1m long and handfuls of mixture are thrown downwards onto it. This line is now compressed into a long “swiss roll” by turning in the side edges and squeezing with the fingers and thumbs. The resulting roll is around 1 metre long and 7 cm diameter. Around 5 such rolls are required to fill the mould.

### 2. *Packing the mould:*

The wooden outer mould is made wet and sprinkled with ash. Polythene pieces are laid over the corner struts to prevent sticking. The inner (firebox) mould and a small banana stem for the chimney are placed as in Figure 2-3. The rolls are laid around these to fill the outer mould, packed tight and levelled with a trowel.

---

<sup>4</sup> This stove is also known by its original name “Unicef stove”

Figure 2-3 Mould for Dembe Stove

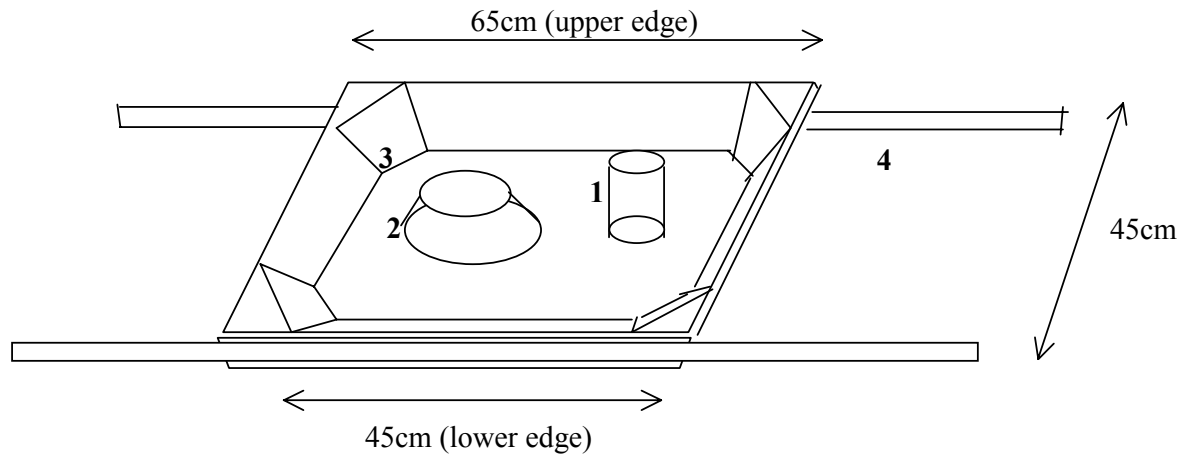

1: chimney inner mould (diameter 12cm), 2: firebox inner mould (top diameter 16.5cm, base diameter 27.5cm), 3: corner struts, 4: handles

### 3. Assembling the stove:

The mould is turned out and placed on wet ground (sand) with the narrower edge at the bottom. This will form the lower half of the stove. The space between the firebox hole and the chimney hole is cut away as a channel (width same as chimney hole diameter). An entrance to the firebox is cut away as shown. A banana stem is placed in this entrance for support. A second form is turned out from the same mould on top of this base, with the narrow edge at the top. Nothing is cut away from the upper form. Finally the stove is smoothed with a wet trowel and sprinkled with sand. A chimney is added after some weeks.

Figure 2-4 Lower half of Dembe stove (Mould turn-out seen from above)

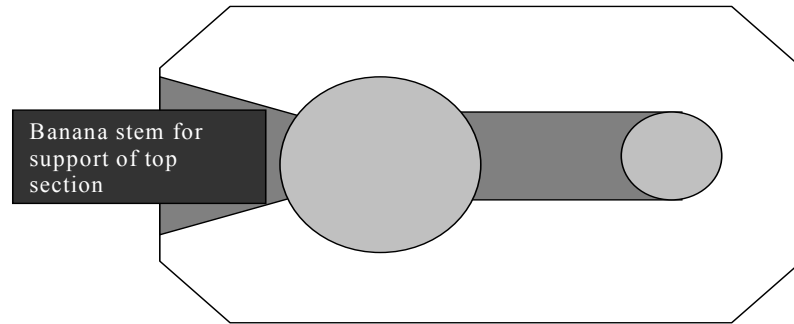



-  Holes for firebox and chimney made by moulds
-  Holes for air channels and firebox entrance cut away from lower form only

Figure 2-5 Side cross section of Dembe stove



Chimney is added after three weeks using the same mixture to form rolls and placing them in layers around the chimney hole.

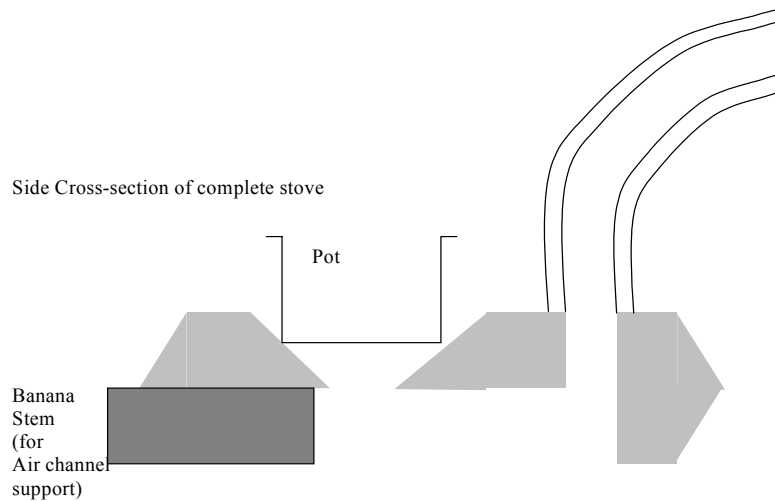

Figure 2-6 The Dembe stove

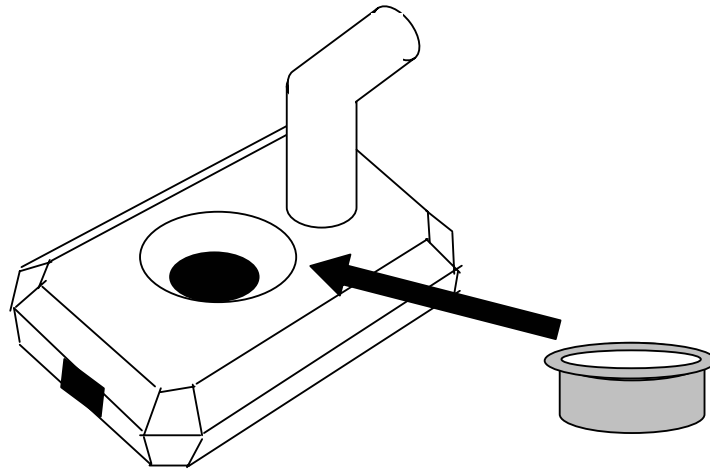

### 2.3 Shielded Three-Stone Fire

The shielded 3-stone fire was constructed using the same AHS:sand mixture described in Lorena construction. Three bricks (8cm by 8cm by 17cm) were placed on end in a triangle formation and handfuls of mixture were used to fill the space between as shown in Figure 2-8. The firebox entrance was supported by a banana stem to prevent collapse. Three supporting knobs of mixture were formed so that it was possible for air to flow past the pot sides. The sides of the stove allowed a 2cm gap around the pot sides and ended 5cm from the pot base.

Figure 2-7 Side Cross Section of Shielded 3-stone Fire

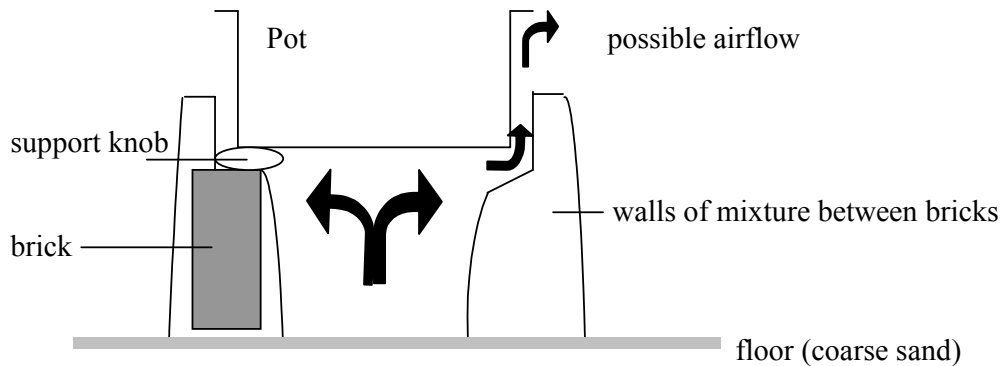

*Figure 2-8 Horizontal Cross-section of Shielded 3-stone Fire*

Inner diameter 20cm  
Height (floor to pot base) 21cm  
Firebox entrance diameter 13 cm  
wall thickness around firebox 8cm  
wall thickness around pot 3cm

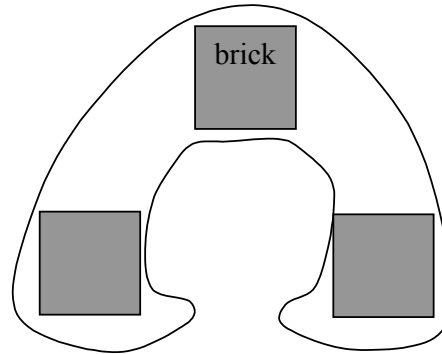

**Common variations:**

- There are various designs for this stove, some are built to fit the pot more tightly, preventing airflow past the pot sides, and a chimney is added.
- It is also common to use bricks as a base layer, to elevate the stove
- Natural stones are also used, although in Kampala and many other areas in Uganda bricks are available and often preferred. It is anticipated that the choice of bricks/stones would significantly affect insulation properties and therefore possibly efficiency.

## 2.4 Metal Woodstove

The metal woodstove was constructed from sheet steel. It was designed to fit the same pot as used with the stoves above. It is in the form of a cylinder, the fire is built on a grate 3cm above the base, with small air holes cut in the side of the cylinder below. A hinged door 14cm high by 15cm allows fuel charging. The pot is supported by three small pot rests at a height of 16cm above the grate. The sides of the stove cylinder surround the pot, leaving a gap of 0.7cm for airflow, and finish 2cm from the top of the pot.

Figure 2-9 The Metal Stove

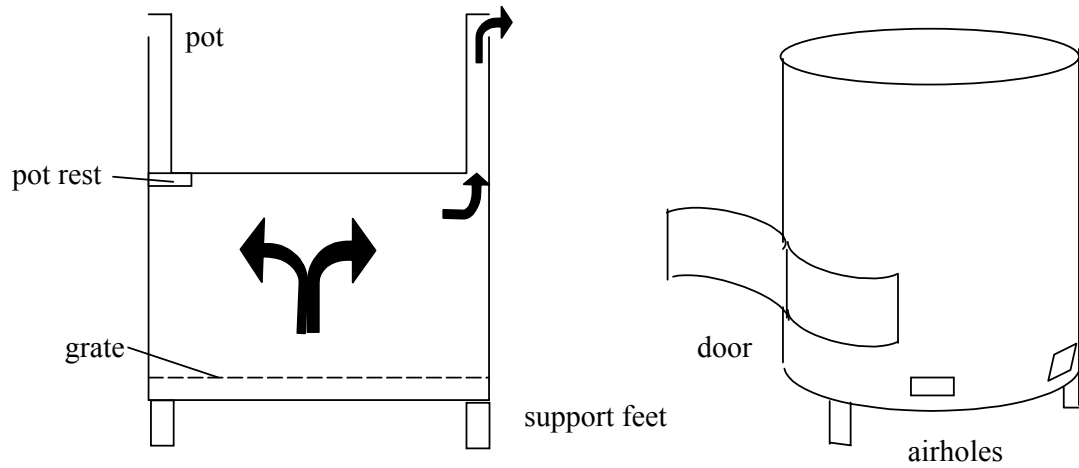

## 2.5 Three-Stone Fire

Three bricks arranged to support the pot, with the pot base approximately 16 cm from the ground (coarse sand)

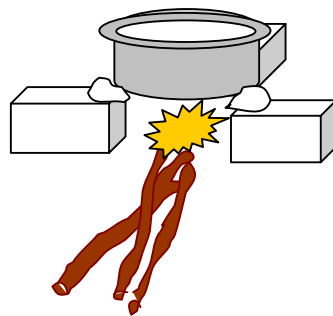

Natural stones are also used, but bricks are often preferred.

## 3 Background to Methodology

### 3.1 Relevant Measurements

It is not possible to give one figure to represent the performance of a stove. Its efficiency will vary depending on the power level required and time since lighting, among other factors. Three tasks have been selected for the stoves in order to assess their performance.

#### 3.1.1 High Power Measurements

It is clear that it is important for a stove to perform well **at high power**, since most cooks will want at least the initial phase of cooking to be at high power to, for example, bring water to the boil quickly. Some meals may require only a high power warm-up phase, and no prolonged simmering, or slow cooking in an insulated hay-box. Thus one test will be performed exclusively at high power.

In order to extend the high power phase beyond the short time required to heat such a pot to boiling, a high-power boiling phase is used, and the mass of water boiled away measured (no lid is used). In this way, the energy to turn water into steam is considered to be useful energy, as it could conceivably be used (in a different way) by a cook. There is, of course, no practical use for high power boiling in the cooking process, since the boiling temperature cannot be raised in this way. The test is simply to calculate the maximum power; in the kitchen, the cook will use this max power only when water etc. is below boiling point.

It is intuitive that some stoves, particularly high-mass stoves, will not reach maximum power for some considerable time after lighting. However, in most real kitchens, cooking will start on a cold stove and burning wood to pre-heat the stove can never increase overall efficiency. For this reason, the test will start from cold, and boiling will not continue for more than 30 minutes.

#### 3.1.2 Low Power Considerations

It is perhaps even more important that a stove should allow for sufficient **turndown** to keep food simmering without wasting energy by vigorous boiling. This will be very significant for overall fuel consumption, especially for slow-cooking beans, lentils etc. Once boiling point is achieved, the stove must simply replace lost energy to prevent the temperature from dropping. A theoretical

perfectly insulated pot/lid would require no further power to maintain near-boiling temperature indefinitely.

Thus, in order to reproduce a more realistic overall consumption figure for a typical cooking process, water is heated, covered by a lid, on max. power to boiling, and then the power is reduced so that water is just boiling for 90 minutes. The stove operator uses his/her skill to waste as little energy as possible while maintaining simmering temperature. The consumption figure will thus reflect user skill (inevitably) and effectiveness of the pot-stove-lid combination. It is difficult to give a meaningful efficiency at simmering power. (The energy required to boil simply reflects the “inefficiency” of the pot-lid combination. Even if this is considered to be energy used, it is difficult to measure since a lid precludes the possibility of measuring water mass lost to steam, whereas simmering without a lid requires much more power). So the main purpose of this test will be to compare stoves to each other, the emphasis being on fuel savings realised.

However, fuel consumption and savings are only meaningful if it is assumed all stoves are performing the same task. This is only true if the cook requires only one pot to be simmering for 90 minutes, and the second lorenna pot is therefore redundant. In some cases, this will be true, as often one ingredient must simmer for much longer than others, but at other times it will be useful to heat a second pot for tea, sauce etc. Considering this, the fuel consumption figures are somewhat unfair to the two-pot lorenna, which performs more work as it heats an additional pot in this test.

For this reason, “efficiency” figures have also been calculated, in order to allow fair comparison between the two-pot lorenna and other stoves. They take into account the energy used to heat the second pot. These efficiency figures assume no energy is required to *maintain* simmering temperature. The energy used in turning water to steam is not considered useful energy, since the cook has done all that can reasonably be expected to minimise this loss (ie. use a lid). In no real kitchen would this energy be usefully harnessed. The test assumes the cook only requires the water to simmer. This is in contrast to test one, where energy used to make steam was calculated as useful energy on the assumption that a proportion of it could be used in certain cooking situations where high power is required. This harnessing of steam energy is illustrated in test three, the meal-cooking test, where bananas are steamed.

It is important that only the energy required to heat the water to boiling is counted as useful in test two. Any further energy supplied simply replaces energy lost through pot walls, the lid or with escaping steam. This test will evaluate the combination of stove + pot + lid, with a “perfect” system requiring only energy to initially heat the water. The necessity of this approach is illustrated by considering a stove which is efficient at high power, but does not allow for any turndown (it can only burn at high power). This stove will use much more energy than necessary to maintain boiling temperature for 90 minutes, and this must be reflected in any efficiency figures. If the energy used to turn water to steam were considered useful, this “high power only” stove would also give a good efficiency for the simmering task, although it has used much more fuel than a “power controllable” stove to do the same job. Other stoves would be able to provide low power and avoid wasting energy through vigorous boiling and steam production.

In order to reflect this, steam production cannot be considered useful when low power only is required.

Therefore the efficiency figures given for test two can be used to accurately compare the stoves to each other at low power, but it must be remembered that they should not be compared to efficiencies for test one, which are calculated to include steam production as useful energy.

This test will also be conducted without a lid for the three-stone fire, to evaluate any fuel savings effected by the lid.

### **3.1.3 Meal Cooking**

Finally, it is necessary to actually perform a meal-cooking task on the stove, this is partly to ensure that the water boiling tests were representative of realistic use, with regard to local cooking practices etc. The stove power levels and cooking procedure are controlled by a local cook, who prepares a typical meal as quickly as possible using a minimum of fuel. This test has a larger number of uncontrollable factors, such as uniformity of raw food and human judgment (when a dish is “ready”). However, it is clearly helpful in determining fuel consumption for the stove as it is usually used, and is an immediately understandable point of reference for non-scientists, who must be persuaded to promote or purchase an effective stove. Efficiency figures can sound unimpressive!

## **3.2 Tests Performed**

Three tests were carried out on each stove:

### **1. High power boiling test.**

Water is heated as fast as possible and boiled for 30 minutes to determine:

- The highest power the stove is capable of
- The efficiency at that power

### **2. Combined high and low-power boiling test.**

Water is heated to boiling point and simmered for 90 minutes (covered) to determine:

- The fuel consumption in performing such a task
- Any fuel saving as compared to a 3-stone fire in performing such a task.
- An efficiency figure, to allow direct comparison of one and two-pot stoves.

### **3. Meal cooking test**

A typical meal is prepared according to local practices, with power levels controlled by a local cook to determine:

- The energy required to prepare the meal
- The time required to prepare the meal
- Any fuel savings realised compared to a 3-stone fire

### **3.3 Errors and Uncertainties**

The random errors due to uncontrollable aspects of wood-burning, cooking and other factors affect the spread of results for each five identical tests conducted. These effects swamp any quantifiable errors in accuracy of measurements taken. For this reason, the errors in quantities shown have been calculated as for a single physical measurement, even though some (efficiency for example) are clearly the result of calculations involving several measurements. The standard error approach has been used on the spread of results.

## 4 Tests

### 4.1 High Power Boiling

#### 4.1.1 Method

Stoves were used starting from “cold”. The stoves were newly constructed, but had been used at least ten times previous to testing. Wood was recently purchased eucalyptus with a moisture content of  $14 \pm 1\%$ . Altitude was 1200m, air temperature ranged from 20°C (often early morning) to 32°C, thus care was taken to test individual stoves at a range of air temperatures.

- Around 3Kg wood was weighed
- 3.5 Kg water in a 26.5 cm diameter pot was placed on the stove when burning well, no lid was used. Water temperature was noted
- The stove operator brought the water to boiling as fast as possible (i.e. at maximum power), while temperature readings were taken at 5-minute intervals
- Once the water reached boiling point, high power was maintained for 30 minutes
- The water was then re-weighed, and burning wood extinguished.
- Charcoal was separated from remaining wood, and weighed separately.

In the case of the two-pot Lorena, the above procedure was followed for the first pot, while the second, containing 2.5kg water was allowed to heat. Temperature readings were taken at 5 min. intervals.

Tests were repeated 5 times.

#### 4.1.2 Results and Discussion

Power is (energy transferred) / (time taken).

Power was calculated on the basis that temperature rise and mass of water boiled away both represent useful energy transferred to the water. Taking specific heat of water = 4.185j/g/°C and latent heat of water = 2.33Mj/kg.



The power of the stove can be given by:

$$P = \frac{(T_f - T_i)4185m_{wi} + (m_{wi} - m_{wf})2.33 \times 10^6}{t}$$

Where:

T = water temp, i denotes “initial”, f denotes “final”,  $m_w$  = mass of water.

Figure 4-1 shows the power delivered by each stove, when operated to give maximum power.

Figure 4-1 Graph of Maximum Power Delivered by the Stoves

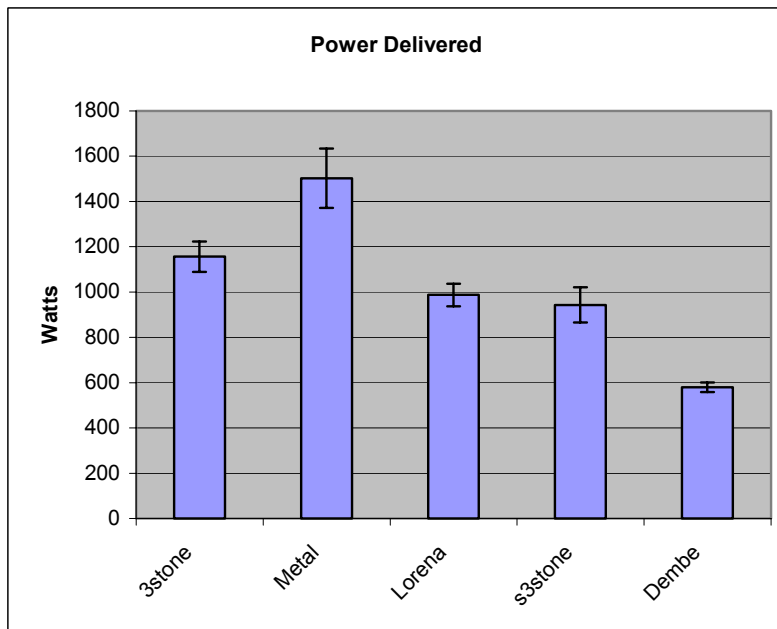

The 3-stone open fire, which will be a point of reference for many, gives 1160W under these conditions. The metal stove gives a maximum power 30% higher. Lorena and shielded 3-stone stoves deliver slightly less. It should be remembered that the 1000W for the Lorena represents power input to two pots; for a task requiring only one the figure would be lower. The Dembe stove delivered an unimpressive 580W, which was barely enough to maintain boiling.

The spread of results for individual stoves gave relative standard errors of 4% (Dembe) to 8% (metal stove). The differences found between stove output powers are outside this range, with the exception of Lorena- shielded 3stone comparison.

Efficiency is the ratio between the energy input to the stove (the wood fuel) and the energy actually transferred to the water.

The energy value of dry wood is around 20 Mj. The value for the (moist) wood used was calculated according to:

$$\text{Energy} = \frac{100 \times 20 - 2.4(54 + \frac{M}{100})}{100 + \frac{M}{100}} \text{ Mj/kg}$$

Where M is the moisture content of the wood, expressed as a percentage of the dry weight. The moisture content was determined by weighing before and after drying in an oven at 110C for 12 hours. The wood used typically contained around 14% moisture, giving an energy value of 18.86Mj/kg.

However, some of the wood mass will not be converted to heat immediately, but into charcoal, which could be burnt later. Charcoal has a higher energy value than wood (30Mj/kg). Any charcoal remaining in the firebox is unused energy, and the “energy in” figure must reflect this.

Thus the efficiency of the stove can be given by:

$$\eta = \frac{(T_f - T_i)4185m_{wi} + (m_{wi} - m_{wf})2.33 \times 10^6}{(m_{cf} - m_{ci})18.66 \times 10^6 - 30 \times 10^6 m_c}$$

Where:

T = water temp, i denotes “initial”, f denotes “final”,  $m_w$  = mass of water,  $m_a$  = mass of wood fuel,  $m_c$  = mass of charcoal formed.

Figure 4-2 gives the efficiency of the stoves when operating at maximum power. The 3-stone fire has shown an efficiency of 16% under these (sheltered) conditions at high power. The shielded 3-stone fire can offer a very slight improvement on this, while the metal stove gives an efficiency 6% (abs) higher. Both Lorena and Dembe produce poorer results, significantly worse than an open 3-stone fire. Again, it must be remembered that the Lorena has two pots, and energy given to both contributes to the figure.

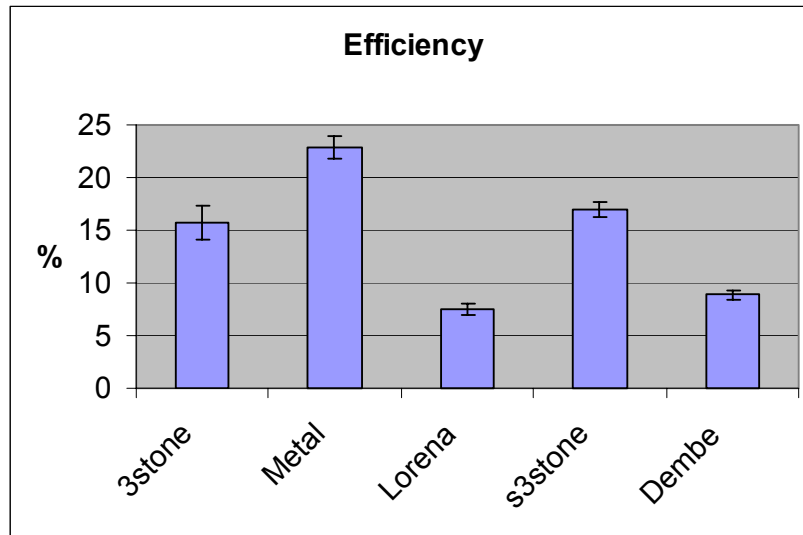

Figure 4-2 Graph of Efficiencies at Max. Power

A cooking task requiring only one pot would give an even lower efficiency. Three quarters of the total power delivered was given to the first pot. The two high mass stoves have both given poor efficiency figures. It seems that the large volume of dense material is not effective at sending the heat to the right place. The low mass stoves performed much better, implying that the body of the Lorena and Dembe is too conductive. It absorbs heat and does not allow it to reach the pot. This is perhaps not surprising, especially for a relatively short high-power test where the fire is hot and the stoves are still cool.

The spread of results for each individual stove was surprisingly narrow, giving an absolute standard error of between 1.6% (3-stone) and 0.46% (Dembe)

## 4.2 Low Power Boiling

### 4.2.1 Method

- Around 4Kg wood was weighed
- 3.5Kg water was weighed, and placed on the stove when burning well, a lid was used to cover the pot.
- The stove operator brought the water to boiling at maximum power
- Once the water reached boiling point, power was reduced to the minimum level required to keep the water simmering. Simmering (not less than 2°C below boiling point) was maintained for 90 minutes.
- Burning wood was extinguished, and charcoal and wood were weighed separately

The first Lorena pot was treated as described; the second was filled with 2.5kg water, covered, and allowed to warm over the course of the test.

## 4.2.2 Results and Discussion

Fuel consumption was calculated by mass of wood burnt away, taking moisture content into account (18.68Mj/kg) and mass of charcoal produced (30 Mj/kg). (see 3.3.2). Figure 4-3 shows energy consumption for the stoves. Figure 4-4 shows the same data expressed as savings realised compared to the 3-stone fire. All figures are as used with a lid, except where stated.

Figure 4-3 Graph of energy consumption for 90 minute simmering task

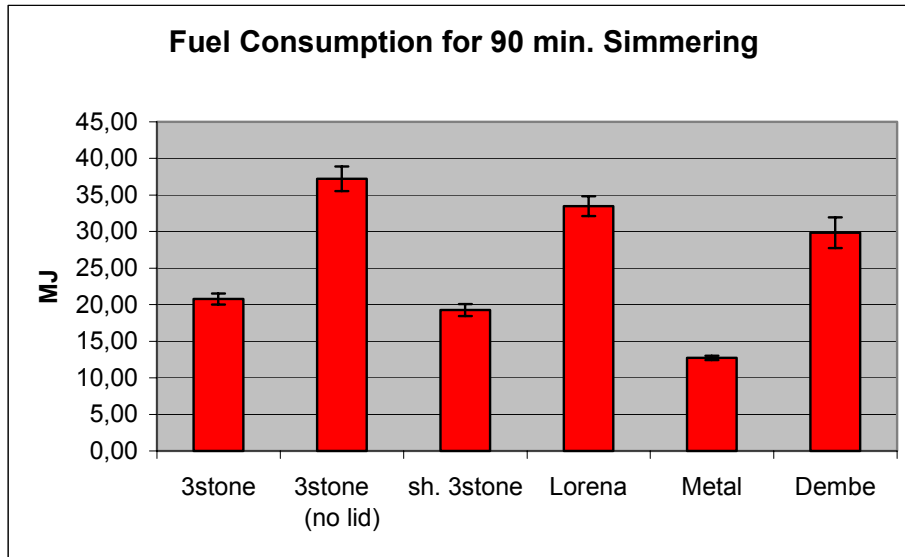
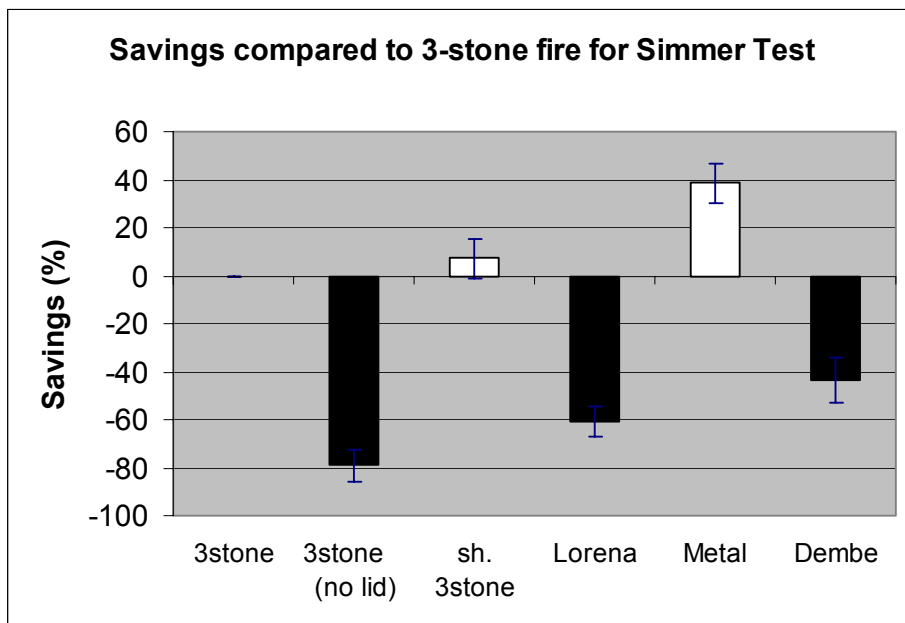

Figure 4-4 Graph of savings realised for 90 minute simmering task



**The most striking result is the dramatic increase in energy required when simmering without a lid. Nearly 80% more fuel is needed to maintain the temperature. It is clear that this effect is more significant than the type of stove used.**

A lid blocks evaporated steam from leaving the pot, taking energy with it. Vapour condenses on the cooler lid and drips back to the pot. In the process, it releases energy, warming the lid and the air inside the pot. This helps to maintain temperatures in the pot by minimising the constant loss of energy due to evaporation of water. The uncovered pot lost an average of 2.1kg of water to steam, whereas the covered pot lost only 0.4kg. The difference represents 3.9Mj of latent heat. It must be remembered that the 3-stone fire showed an efficiency of 16%, so for the extra 3.9Mj given to the pot, 25Mj of extra wood must be burnt<sup>5</sup>. However, since not all of the 3.9Mj can be reclaimed by the lid, the result is a 16Mj difference in fuel consumption. Some of this may also be accounted for if it is assumed that the fire burns less efficiently at high power, and a higher power is required to maintain boiling without a lid.

The three-stone fire used 21Mj to perform this task, equivalent to just over 1kg of wood (worth 100Ush or 6 US cents), while the metal stove offered the best saving on this, 40%. The shielded 3-stone fire also gave a slight saving, while Lorena and Dembe stoves consumed considerably more energy to do the same job. It should be remarked that this test is somewhat unfair to the Lorena, since it performs more work than the other stoves. In addition to heating and simmering the first pot, it also heats a second pot with 2.5kg water to an average of 62°C. In fact, if steam production is not included as useful energy, the first pot receives two thirds of the total power. **These consumption figures assume that the user requires only one pot to cook.**

The efficiency figures shown in Figure 4-5 assume that both lorena pots are heated usefully. They do not assume that steam production is useful work done<sup>6</sup>, and for this reason should be compared only to each other – not to efficiencies for test one.

Only the energy needed to heat the water to boiling is included as used energy, in this way the efficiency is given by

$$\eta = \frac{(T_f - T_i)4185m_{wi}}{(m_{of} - m_{oi})18.66 \times 10^6 - 30 \times 10^6 m_c}$$

Where:

T = water temp, i denotes “initial”, f denotes “final”,  $m_\alpha$  = mass of wood fuel,  $m_c$  = mass of charcoal formed.

---

<sup>5</sup> This calculation is intended only for illustration purposes. It assumes that the efficiency of the fire is the same at all power levels and pot/water temperatures.

<sup>6</sup> See 3.1.2 ”Background to methodology – low power considerations”

Figure 4-5 Graph of Efficiencies for Simmer Test

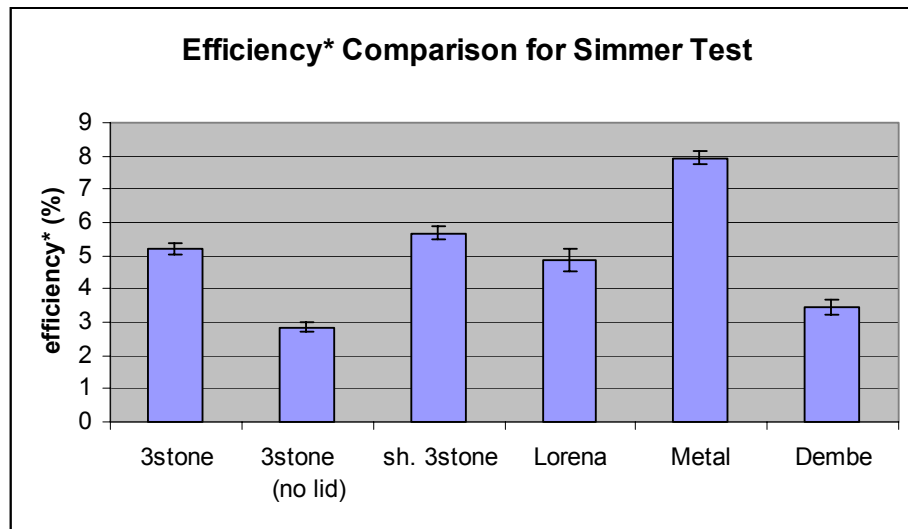

\* These efficiencies do not include steam production as useful work done, and should not be compared to **Figure 4-2**.

The high mass Lorena and Dembe have failed to perform better than the 3-stone fire, even over a longer, less intense heating period. Although the stove bodies were warm to the touch after an hour or so, they were at no time hotter than the pot. The warm stove body surrounding the pot can help to reduce heat losses from the pot, but it will not actively heat it up unless it is hotter than the pot itself. The vast majority of the energy absorbed by the stove body does nothing to heat the pot contents. This is a very wasteful process. The light metal stove, on the other hand, absorbs much less heat. Since it gets very hot, it radiates some heat out to the room, but this effect is much less significant than the conduction of heat away through the body of the high mass stoves. It is also, apparently, less significant than the loss of heat to the air by the 3-stone fire.

## 4.3 Meal Cooking

### 4.3.1 Method

The test was performed by a Ugandan housewife. She determined cooking methods, quantities, power levels and identified when the meal was ready. Banana leaves and sticks are used in the cooking process, but are not eaten.

- 400g sticks (of banana leaf back ridges) were placed in the bottom of the pot and covered with 2kg water.
- 1.5 kg banana leaves was weighed and from these two large leaves were used to wrap 3kg whole peeled matoke (savory cooking bananas), which were placed in the pot.
- A sauce was prepared: 350g mashed G-nuts (peanuts), 60g chopped onion, 160g chopped tomato, 10g salt and 1kg water was mixed in a small aluminium pot with fitted lid (diameter 18cm, capacity 1.5 litres).

- The small pot (with lid) was placed on the matoke bundle in the big pot, and everything was wrapped around tightly with banana leaves and tied together in a large bundle, which protruded around 30cm from the top of the pot.
- Around 3kg wood was weighed out
- The fire was lit, and the meal cooked. Initially at high power, once the base water boiled, power was reduced somewhat, but not to a minimum level as for test two. The water could be heard to boil fairly vigorously, although only small wisps of steam escaped from the tight leaf-bundle.
- The cook determined the end of cooking time; this should be when most of the base water has boiled off.
- Remaining wood and then char was weighed
- A taste test ensured the meal was properly cooked

When testing the Lorena, the sauce was cooked on the second (smaller) pot hole, in the fitting pot.

### 4.3.2 Results and Discussion

Energy consumption was calculated via fuel wood burnt and charcoal produced as in 3.3.2. Figure 4-6 shows the energy consumption for the above meal for each stove.

Figure 4-6 Graph of energy consumption for meal-cooking task

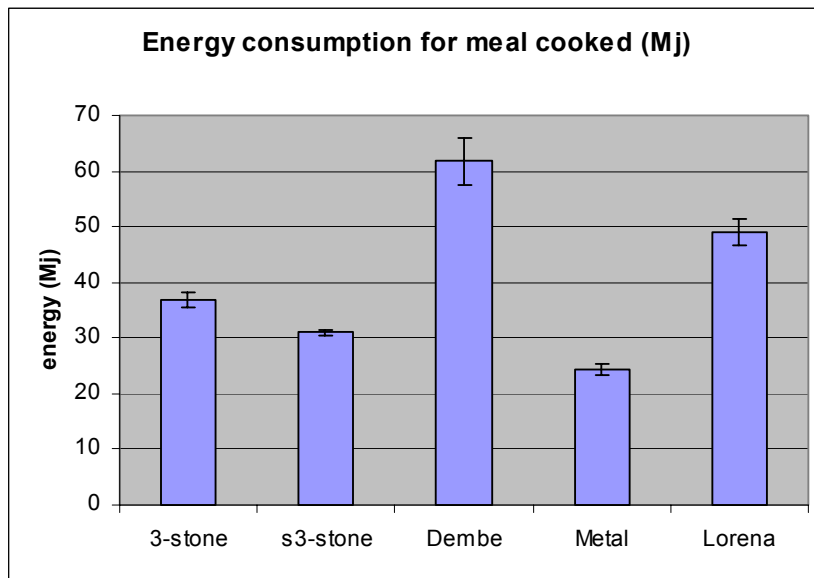

The metal stove has again come out best, using only 18Mj or around 1kg of wood, just over half that consumed by the 3-stone fire. Dembe and Lorena needed considerably more. The data is shown in Figure 4-7 as percentage fuel savings.

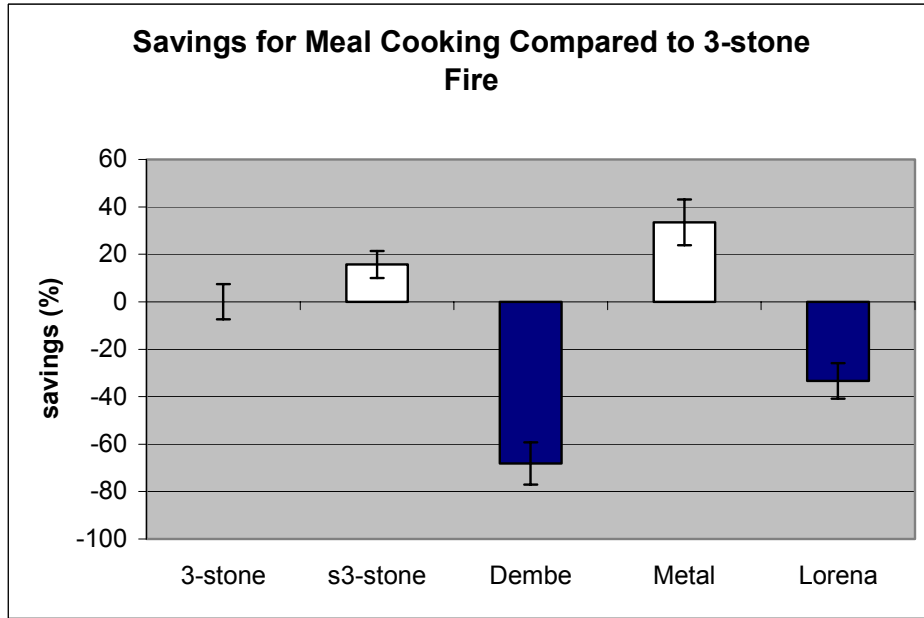
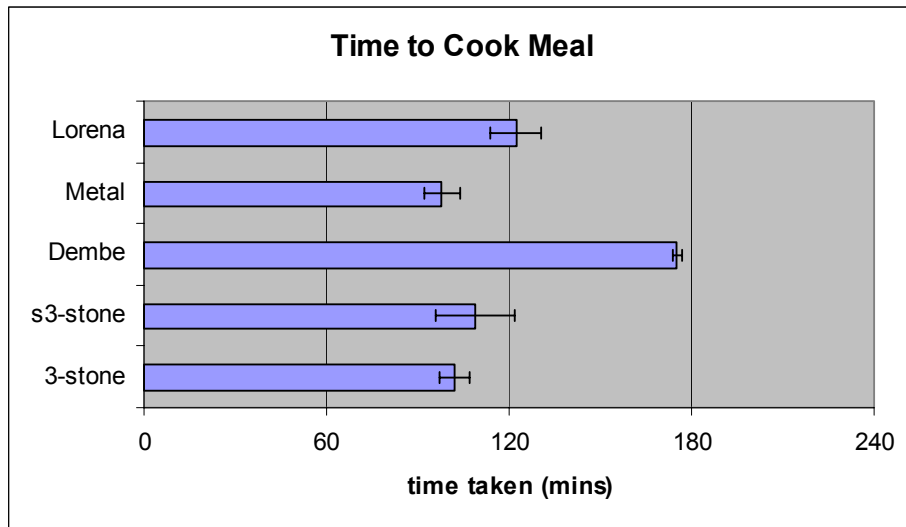

Figure 4-7 Savings realised for meal-cooking compared to 3-stone fire

This presentation highlights the disappointing Dembe performance, using just under 70% more fuel than the three-stone fire to do the same job. The savings offered by the metal stove are certainly significant, but possibly not dramatic enough for users to notice without consciously measuring fuel used.

The time taken for the meal to cook is also relevant to users, this is shown as Figure 4-8.

Figure 4-8 Graph of time taken for meal-cooking task



Although the metal stove has given the fastest meal-cooking time, the differences between the first four stoves are not great, lying between 82 and 122 minutes with overlapping error bars. The Dembe however, stands out with its sluggish 178 minutes – an hour’s extra wait for dinner.

This particular meal involves a steaming process. The cooking time seems to be determined by the matoke, not the sauce. The sauce simply simmers until the



matoke is ready. The cook decides when the meal is ready by listening to the sound of the base water boiling. When this has nearly boiled away completely, the meal is ready. The rate of water-boiling is necessarily determined by the power level the stove provides. The power levels used by the cook were below the maximum power used in test one, but considerably higher than simmering power. The fuel in the 3-stone fire was consumed at 80% the rate of that used in test one. It was clear in test one that the Dembe is not capable of delivering 80% of the maximum power of the 3-stone fire. Thus, the optimal (according to the cook's preferences) power level cannot be achieved with the Dembe, and the water takes longer to boil away.

It is not obvious (to the author) that a given mass of steam must pass through the bundle before the meal is cooked, regardless of time, but the method appeared to work this way, as none of the meals was over- or under-cooked. The danger of a stove giving too much power and boiling away the water before the food was actually ready did not seem to be a problem here, probably because the cook controlled it not to do so. If this is the case, then the 100minutes approximated by four of the stoves represents a minimum cooking time for this meal, which the Dembe cannot achieve.

It should be noted that while this method of steaming two pots bundled together is relatively common in Uganda, there are other methods and meal types requiring two or more dishes to be prepared separately. In this case, the stoves designed for only one pot would be at a disadvantage compared to the two-hole Lorena.

## 4.4 Summary of results

Test 1:

No stove gave a higher maximum power than the three-stone fire except for the metal stove, at 1500W. It was also the most efficient at high power, giving 22%. The Lorena and shielded 3-stone fire gave a maximum power around 950W, While the Dembe was much lower at under 600W. The efficiency for the Lorena was the lowest at 7%, with the Dembe faring only slightly better.

Test 2.

The metal stove gave the lowest fuel consumption for the 90 minute simmering task, followed by the 3-stone and shielded 3-stone. The Lorena and Dembe used considerably more fuel to perform the same task. However, if efficiency figures accounting for *both* Lorena pots are considered, the Lorena was only slightly less efficient than a 3-stone fire. The effect of removing the lid on fuel consumption proved to be greater than the stove type used, an 80% increase in fuel consumption was shown.

Test 3

Four of the stoves used approximately 100 minutes to cook the meal, while the Dembe used around an hour more. Fuel consumption was greatest for the Dembe, followed by the Lorena. The metal stove again used least fuel. The shielded 3-stone fire offered a small saving compared to the 3-stone.

## **5 Improvement of Designs**

### **5.1 Basic Principles of the Burning and Heating Process**

It is clear from the test results that the Lorena and Dembe stoves have design flaws preventing effective energy transfer from the wood to the pot. It is equally clear that the metal stove is doing something right. The author aims to establish some general principles that improve efficiency in stove design, and apply these to choose a stove design suitable for the user needs of Ugandans.

There are two aspects to the transfer of energy from the wood to the pot. The first is the combustion process, which releases heat; the second is the transfer of the heat to the pot.

The overall efficiency is therefore the product of the efficiency of the first process (Nominal Combustion Efficiency) and the second (Heat Transfer Efficiency). A high combustion efficiency has the added benefit of reducing emissions, whether to the kitchen or the outside environment.

#### **5.1.1 Combustion**

The combustion process converts chemical energy in the wood to heat. This happens in two stages. At temperatures of above 250°C, the combustible components of the wood are vapourised; this process is known as pyrolysis. The vapour then combusts, releasing heat, which in turn causes further pyrolysis. Inevitably however, combustion is not complete, especially at lower burning temperatures. Some of the (burnable) carbon within the wood escapes unburned as smoke etc. (Khan 1999)<sup>7</sup> This is wasted energy. In order to achieve more complete combustion, the fire must burn hot and clean.

Flames in contact with cool walls or a cool pot will not burn efficiently. Packed earth such as that used in the Lorena and Dembe conducts heat away quickly (Still and Winiarski, 2001), resulting in relatively cool firebox walls. Insulation around the firebox, especially in high mass stoves, is clearly paramount.

---

<sup>7</sup> reported in Rouse (1999)

In addition, all parts of the fire where combustion takes place must receive enough air to allow oxygen to participate in the reaction. The formation of charcoal indicates insufficient air access in the stoves tested so far. The volume of the fire must therefore be limited, to ensure no part of it is inaccessible to air. Also, a stronger airflow through the stove can be achieved by channeling the flue gasses up an “inner chimney” inside the stove as shown in Figure 5-1. However, an increased intake of cold air from outside the stove will cool the fire, resulting in less efficient combustion. If possible then, the air should be warmed before reaching the fire. These principles are incorporated into the “rocket elbow” shown below. This represents the lower part of the stove only.

Figure 5-1 The rocket elbow

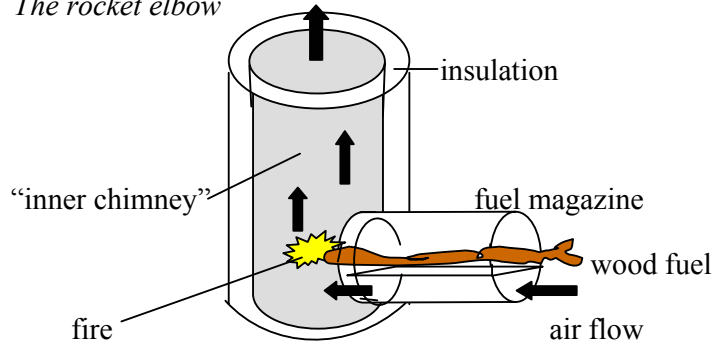

The insulated firebox is extended upwards into a chimney, creating a draught, which helps to suck air in. The air must come through the fuel magazine, under the fuel, which rests on a shelf. The fuel magazine becomes warm, heating the air before it reaches the fire. The fire itself burns the tips of the sticks as they enter the firebox. The sticks are spaced to allow air to flow around them. Smoke (uncombusted material) moving up the inner chimney has a good chance of being burnt itself before reaching the pot.

### 5.1.2 Heat Transfer

It is now desirable to ensure the highest possible proportion of this heat converted in combustion reaches the pot, minimising losses. Again, it is clear that the inner stove should be insulated if a minimum of heat is to be lost. In this way, the insulation around the firebox serves a double purpose.

Inevitably, some heat will be lost with the hot flue gasses, whether or not a chimney is used. The Dembe stove in particular suffered because much of the heat was sucked out of the chimney very quickly, without being allowed proper contact with the pot. Before the hot gasses leave the stove then, we must try to extract from them as much heat as possible. To do this, a large area of the pot should be exposed to the gas, preferably the sides as well as the base (Still and Winiarsky, 2001). This means the pot must be submerged in the stove, as it was in the metal stove tested earlier.

More heat can be extracted if the hot gas is forced to rush past the sides of the pot, so the gap between the pot side and the stove wall should be kept small. The

airflow speed within the stove will be constant if the area perpendicular to its flow is kept constant. In other words, the cross sectional area of the inner chimney should equal the total area of the gap left around the pot. If the same rule is applied to the space under the pot, a tapered shape emerges (Figure 5-2).

Figure 5-2 A constant cross-section for airflow around the pot

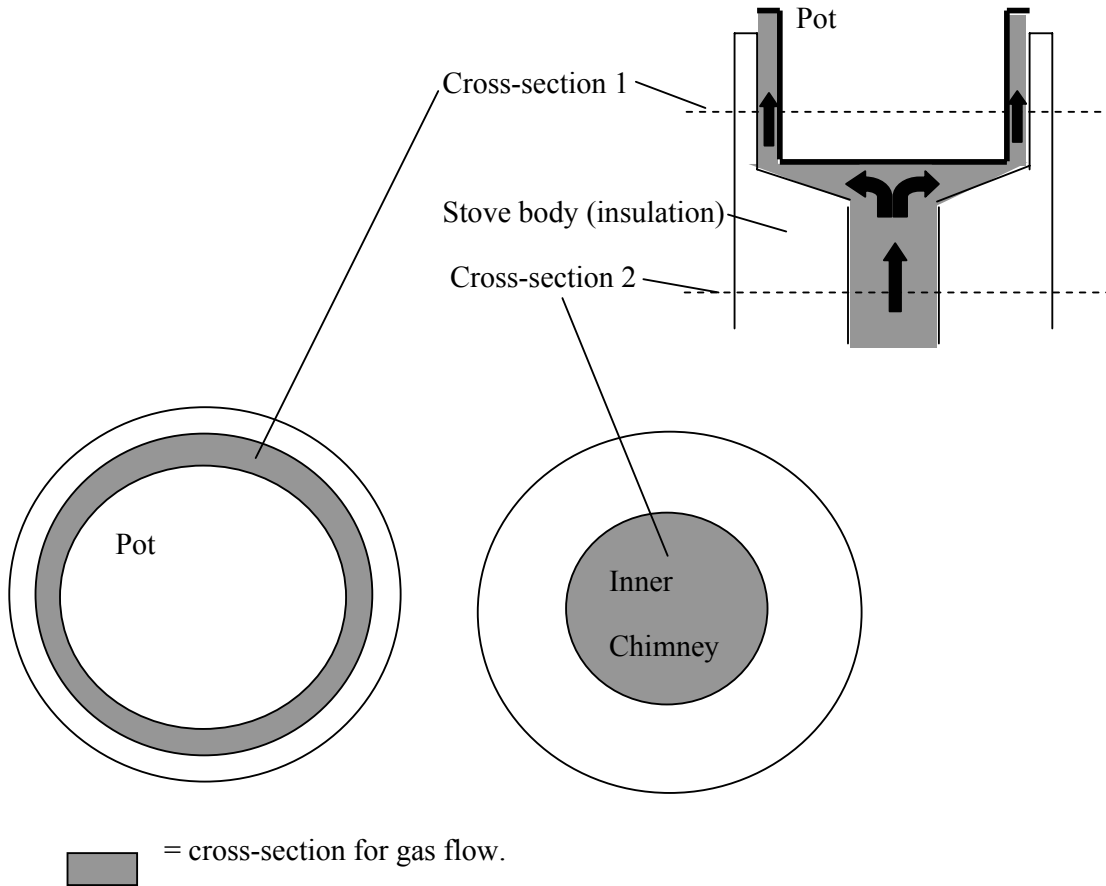

*Cross-section 1 = Cross-section 2.*

The conduction of heat from the gasses to the pot is a function of the temperature difference between the two. For this reason, the flue gasses should be as hot as possible. In the previous section, the importance of adequate airflow through the stove was emphasised. However, if the heat produced is carried by a large volume of air, its temperature is inevitably lower. The airflow must therefore be controlled to an optimal level, balancing the benefits of good combustion efficiency (high enough) and heat transfer efficiency (low enough).

## 5.2 Smoke Removal

Although the rocket stove tends to burn cleanly, it is still desirable to remove potentially harmful smoke from the kitchen. If the addition of a chimney does not reduce the efficiency unacceptably, this could be done by preventing the escape of gasses around the top of the pot sides.

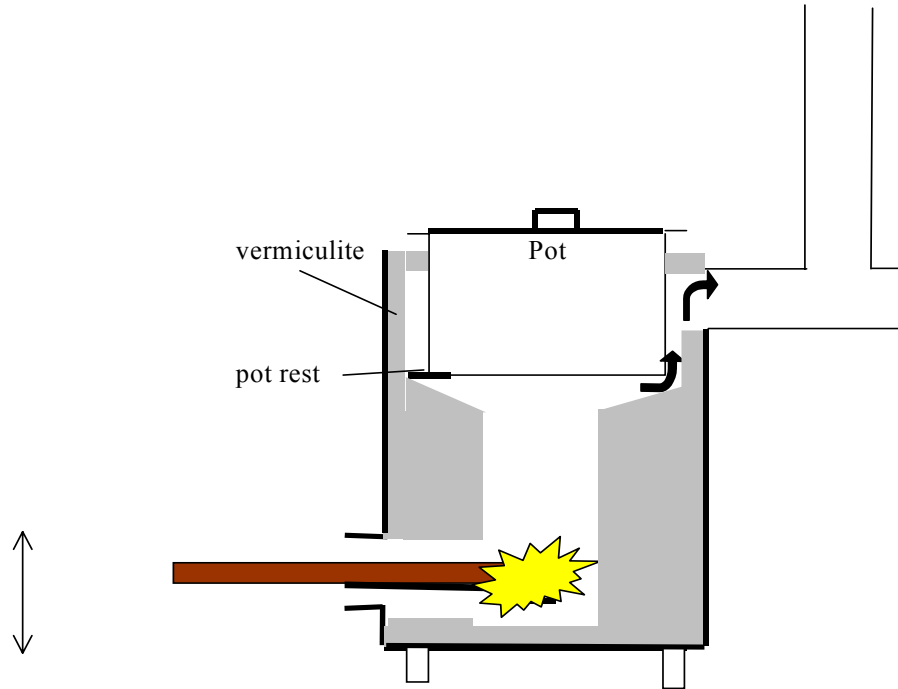

*Figure 5-3 The Rocket stove*

These design principles are combined in the rocket stove shown in Figure 5-3. It is similar to the Winiarski rocket stove<sup>8</sup>, and many design features and dimensions are used as advised by Dean Still.

If two pots are desired, a second could easily be added.

---

<sup>8</sup> The Winiarski rocket stove can be viewed at <http://www.efn.org/~apro/atrocketpage.html>

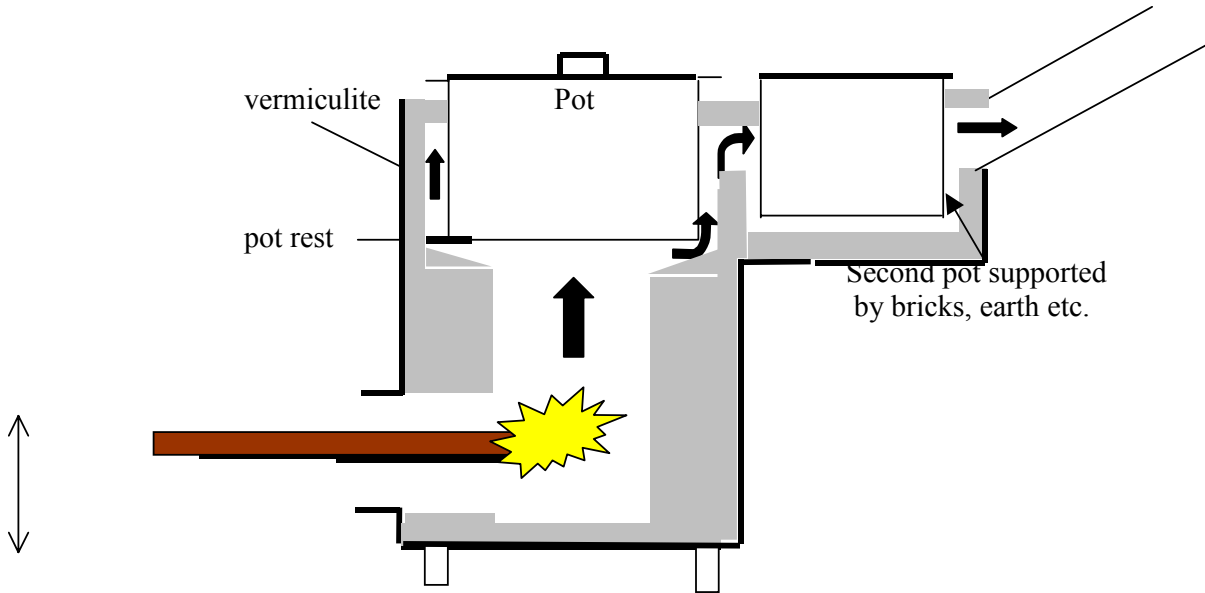

Figure 5-4 The two-pot Rocket stove

The “Estufa Justa” stove also incorporates many of the principles outlined; it was developed in part by scientists from Aprovecho research centre, which was involved with the design of the original Lorena.

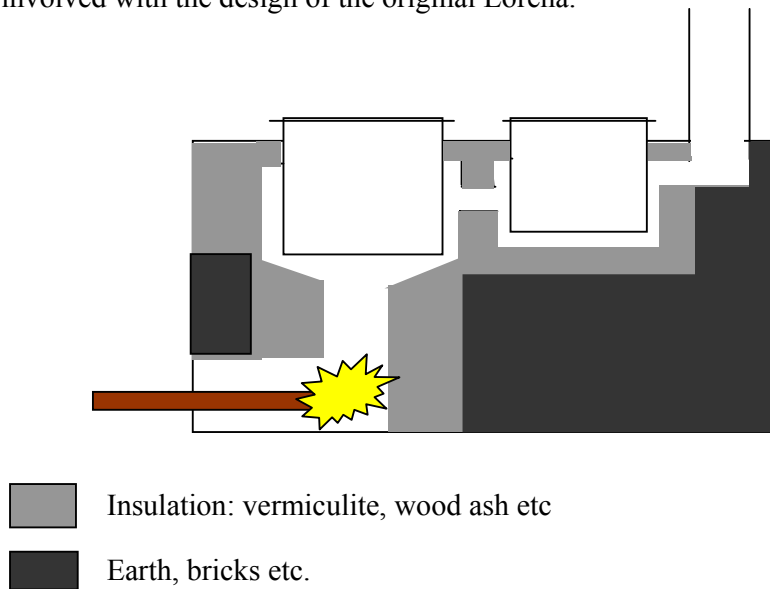

Figure 5-5 The Estufa Justa stove

### 5.3 User Needs and Perceptions

Many stove programmes have failed due to unpopularity. The potential users must perceive benefits from the stove which outweigh the considerable expenditure (as a proportion of earnings).

## Benefits

**Smoke removal** is one such visible benefit. Education on the negative health effects of woodsmoke could increase its perceived value further.

**Fuel savings** are an important perceived advantage, but users often fail to notice fuel saving (DFID 2000). The case of the Lorena “myth” of a 50% saving illustrates this. Demonstration tests in villages are a possible promotion technique. The “old” versus “new” lorena might be particularly impressive. A simple calculation can illustrate expected financial savings due to saved fuel over the stove lifetime. If fuel is collected, the time saved can be valued according to the benefits of alternative activities.

The **appearance** of the stove can be a perceived benefit, as a status symbol, or just part of the home environment. It is hoped that the appearance of the new stoves will be acceptable to Ugandan users who are familiar with the traditional charcoal stove (not dissimilar to the metal stove) and the Lorena (similar to the Estufa Justa).

## Potential Obstacles:

The **submerged pot** may be an initial cultural obstacle, but promoters from IRDI do not believe it will pose a large problem to dissemination in the long term.

The new stoves are simple to operate, no adjustable air controls are incorporated, there is nothing unfamiliar in the cooking procedure to make potential users sceptical. However, if the user prefers to **see the fire** burning while cooking, she must bend to the level of the firebox entrance. This is in common with nearly all enclosed stoves, but the presence of the rocket elbow narrows the “viewing angle” further. Raising the stove using bricks would make use more convenient. Another possibility is to angle the rocket elbow upwards to allow the user to see the fire.

**Durability** is important and will directly affect overall financial savings made by the stoves. The vermiculite/cement mixture used sufficed for the testing period, but should be subjected to longer periods of use. The addition of clay could increase durability. See the mixture suggestion in section 5.4

The Stoves in Figures 5-3 to 5-5 are intended to maximise efficiency while keeping **costs** to a minimum. Ideally these designs would be constructed using wood ash or vermiculite with the rocket elbow lined with cast iron or heavy duty steel. Since this would be unrealistic for the budget of a typical rural household, a cement(vermiculite mixture with wire mesh as an inner lining will be used instead.

For some, even this option will be out of reach financially, for this reason, the simple metal stove already tested will be given a chimney and tested as a possible cheaper alternative.

Figure 5-6 Metal stove with added chimney

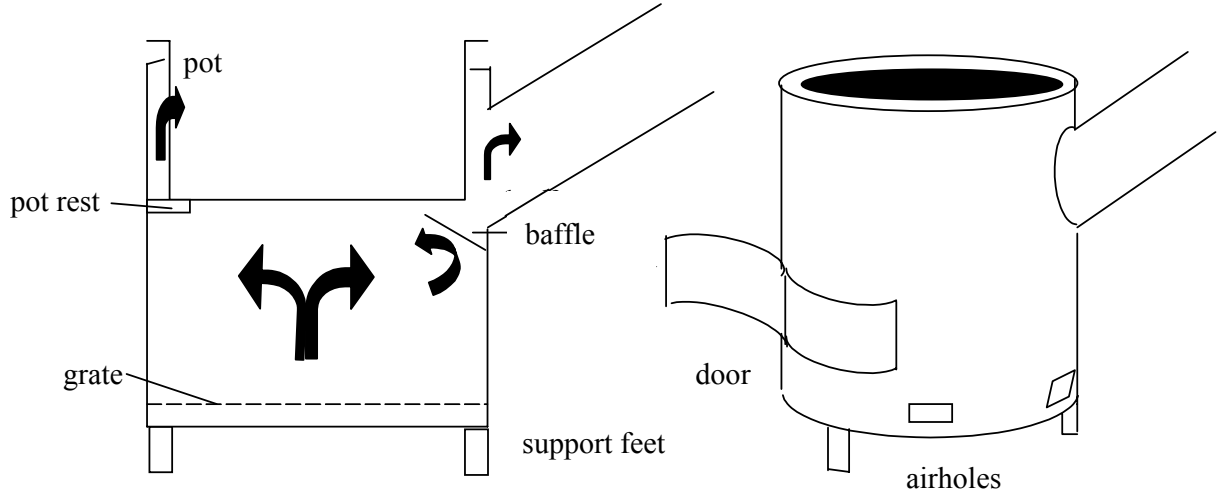

A further cheap and simple option can be constructed by altering the 3-stone fire using a vermiculite/cement mixture. This option will not remove smoke, but the rocket elbow feature should result in cleaner burning and less kitchen pollution. A skirt can be added to increase efficiency. This stove would be more efficient if the insulation could be improved. If the outside were formed from lorena earth and the rocket elbow from strong metal, the walls could be filled with ash. A ceramic pot shape would form the skirt around the pot.

Figure 5-7 The improved shielded 3-stone fire

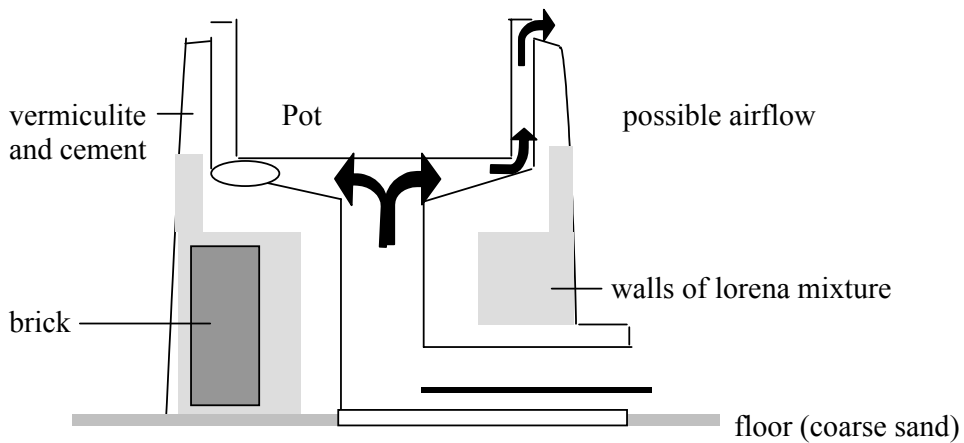



**Safety** may also be a concern for mothers in particular. The metal surrounding the rocket stove may become hot. An outer vermiculite/cement cladding should reduce this considerably. The cheapest and simplest solution to this safety problem might be to build a horse-shoe wall from lorena mud around the stove with a gap at the entrance. This wall should not actually be in contact with the stove, so it would not act as a heat sink. If the wall is built some inches away from the stove, the gap can be used to store wood for drying.

### **Assessing Needs**

It is difficult for a designer to anticipate user requirements, especially as they will vary across the country. **Feedback from users** is essential, so that an iterative process can continually improve on the original design. It is hoped that NGO's and other promoters will co-ordinate to effect improvements based on user recommendations. However, when altering designs, the principles in this section should be considered and, most importantly, stoves should be tested to ensure that efficiency is not compromised unacceptably.

The optimal design for a given community will have to balance initial cost against fuel savings, durability and user health and convenience. Since individuals attach different importance to each of these factors, it may be best to offer a number of alternatives. Cooking practices tend to vary from tribe to tribe, some groups favouring long slow simmering, with the stove in use nearly all day.

## **5.4 Production and Distribution**

The choice of insulation **material** for the stoves will depend on the wealth of the purchaser and **local availability**. Vermiculite transportation may not be feasible. Various mixtures for linings are possible, they should combine strength with insulation properties. Cement or clay can be used to add strength, mixed with ash or sawdust to insulate. A mixture developed by Ken Goyer<sup>9</sup> comprises:

2 parts low fire clay  
1 part high fire clay  
1 part cement  
4 parts sawdust/combustible material

If finances permit, unmixed insulation material such as ash can be held in place with strong metal to form the inner chimney etc. Alternatively this inner support can be ceramic.

The new stoves all require a certain degree of **accuracy** in their construction. Particularly the small gaps around the pot sides must be measured carefully. This may well present problems as most stove construction currently seems to be based on approximate judgements. The importance of accuracy must be impressed on constructors, who should be equipped with a tape-measure. Self construction in the home would present difficulties. Perhaps a few constructors in each village

---

<sup>9</sup> At Aprovecho Research centre, Oregon USA

could be trained and constructed stoves carefully controlled in follow-up visits by promoters.

If the rocket stove is to be constructed in a workshop, it may be difficult to transport with the lining inside. It is very heavy, and **easily broken**.

## 5.5 Stoves Selected

Four improved stove designs were constructed for testing:

**Rocket stove** (see Figure 5-3) constructed from sheet steel outer, with 2:1 vermiculite cement inner lining, wire mesh used to hold the inner chimney shape. Inner air channels are 12cm, diameter chimney is 10cm diameter and 1m high. Vertical elbow is 30cm high. A gap of 1.3 cm surrounds the pot sides, this tapers to 3cm maximum under the pot (nearest the centre). The horizontal elbow was cast iron.

**Metal stove with chimney** (see Figure 5-6) A 10cm chimney at around 45 degrees to the horizontal was added to the metal stove, 70cm long. A small iron square was welded below the chimney preventing hot flue gasses escaping directly without passing around the pot. A steel ring fitting the pot sides was fixed to the stove top to prevent smoke escaping.

**Estufa Justa** (see Figure 5-5) constructed using the original Lorena as a base, with a vermiculite cement mixture reducing the firebox diameter and extending it upwards into an inner chimney 25cm high and 12cm diameter. The gap around the first pot was 1.3cm, later increased to 2cm to allow enough heat to escape to the second pot. A 10 cm diameter 60cm high chimney was added. Steel rings were laid around the pot holes to prevent smoke escaping

**Improved Shielded 3-stone fire** (see Figure 5-7) The original shielded 3-stone fire was altered to include a rocket elbow and pot skirt using a vermiculite cement mix. The inner channels are 12cm diameter, the vertical inner chimney is 25cm high.

The last two stoves were constructed with a vermiculite:cement mix ranging from 2:1 where strength was considered important, to 5:1, where insulation was the priority.

In addition the original **Dembe** stove was tested **without a chimney**, as it is clear the chimney plays some part in the poor heat transfer

# 6 Testing the Improved Stoves

## 6.1 High power

The five stove types described were tested as before, heating at maximum power to boiling, then maintaining maximum power for 30 minutes. The efficiencies at maximum power and the power delivered are shown in Figure 6-1 and Figure 6-2. The original stoves tested previously are included for comparison. For illustration, stoves easily available in Uganda are shaded black.

Figure 6-1 Graph of high power efficiencies for all 10 stoves

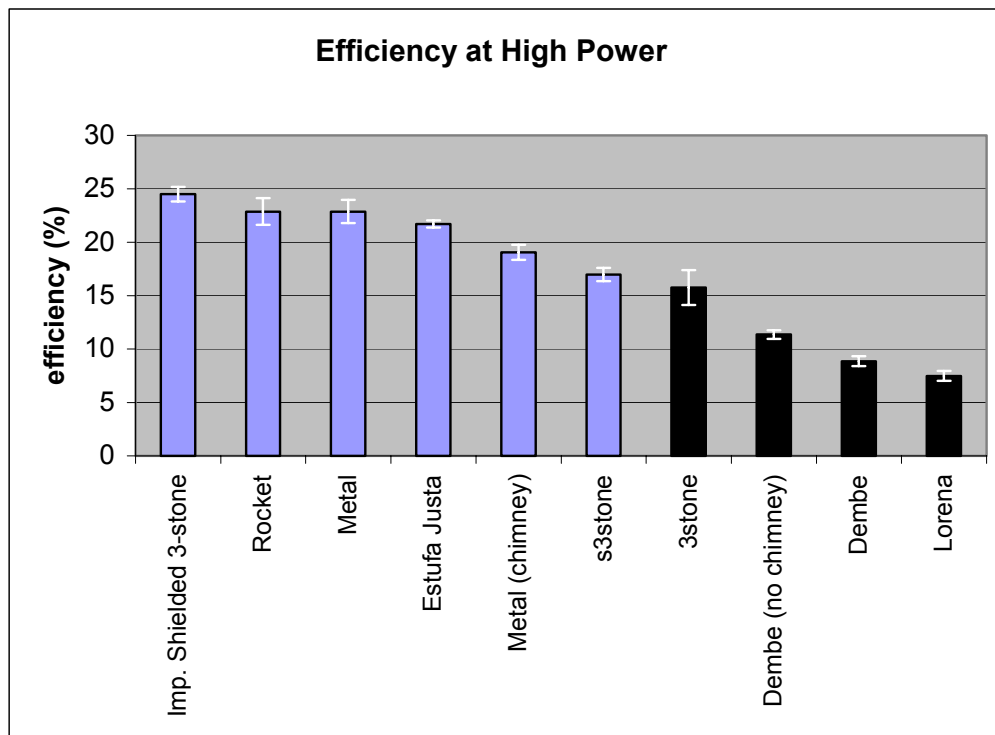
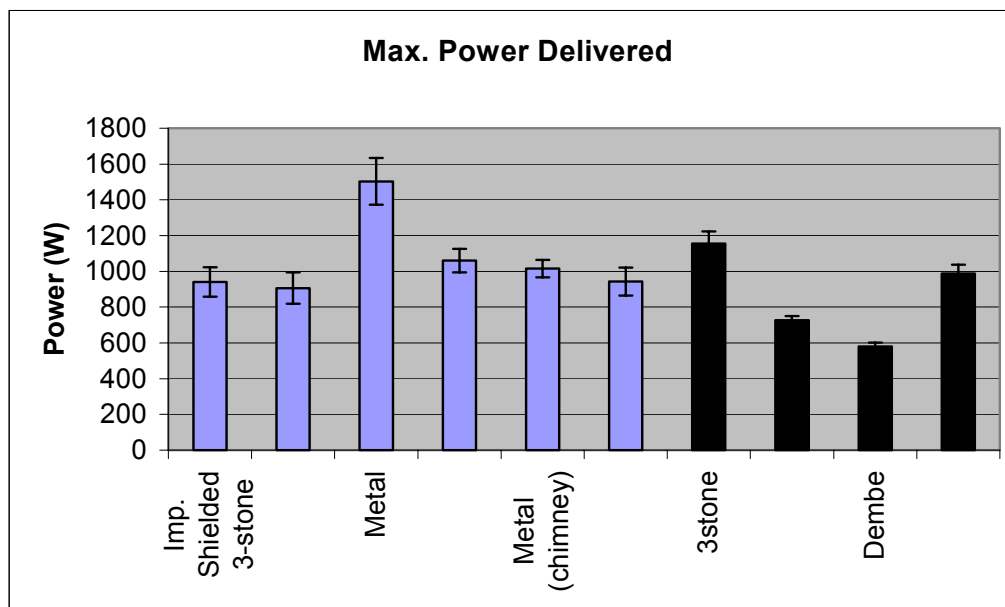

Figure 6-2 Graph to show maximum power delivered for all 10 stoves



The new “improved” designs have all given efficiencies significantly above the three-stone fire.

The alterations made to the shielded three-stone fire have been particularly effective, giving an efficiency just under 25% and a power over 900W.

The Estufa Justa, or “improved Lorena” gives an efficiency over 3 times that of the Lorena. However, the power figure given does not reveal that the power delivered to the second pot averaged only 185W, probably not enough to satisfy most cooks, except to warm dish water. By widening the gap around the first pot to 2cm, this can be increased to 230W, which is comparable to the Lorena’s 245W for the second pot. The result is a drop in overall efficiency to 17.5%, still an enormous improvement on the Lorena.

The rocket stove has given a respectable 23% efficiency, but its relatively low power may prove unpopular. This could be explained by the long internal chimney, and by the high mass nature of the stove. While the vermiculite/cement mix should be a better insulator than earth, it will still absorb and retain a good deal of heat.

The addition of a chimney to the metal stove reduced its efficiency and power considerably. However, many will feel this is well worth it. Swapping a three-stone fire for a metal stove with chimney would remove smoke while reducing power only slightly. The small increase in efficiency would be an added bonus.

Removing the Dembe’s chimney has increased its efficiency, but the stove offers no real benefits to the user or environment. In fact, it is difficult to find any advantages to the Lorena or Dembe stove not exceeded by other alternatives presented in this report.

The Dembe will not be tested further.

## 6.2 Low Power

The simmering test was conducted on the improved stoves as described in section 4.2.1. 3.5 kg water was heated as fast as possible and then simmered for 90 minutes, covered by a lid. The energy required to perform this task is shown in Figure 6-3 for all stoves. The same data are expressed as savings in Figure 6-4. As before, it should be remembered that these figures are meaningful only if one 3.5kg pot of water is needed. If it is useful to heat a second pot simultaneously, the efficiency figures illustrated in Figure 6-5 can be used. This accounts for energy given to the second pot in the Lorena and Estufa Justa stoves. These efficiencies should not be compared to those quoted for the high power test as they do not include steam production as useful energy.

Figure 6-3 Graph to Show Fuel Used in Simmer Test

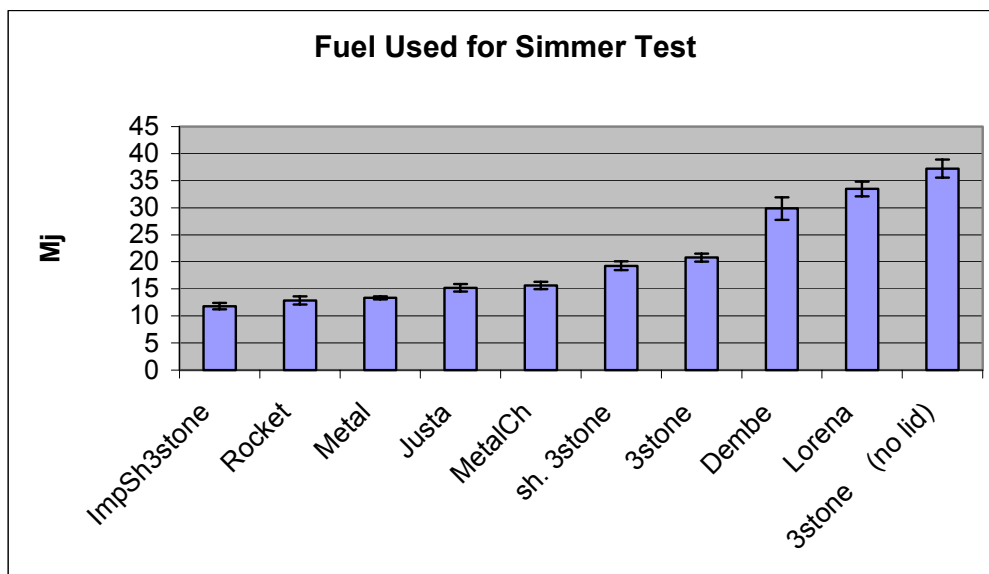

Figure 6-4 Graph to show Energy Savings for Improved Stoves Simmer Test

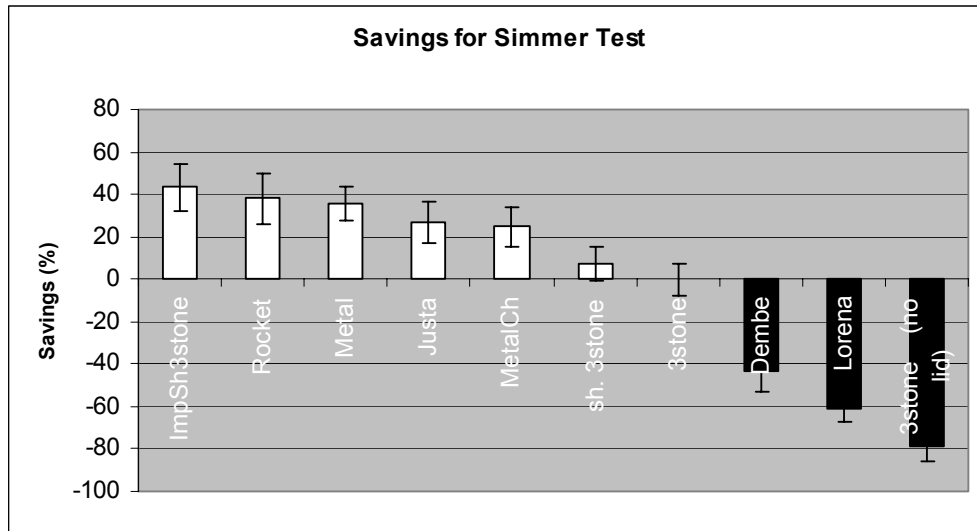
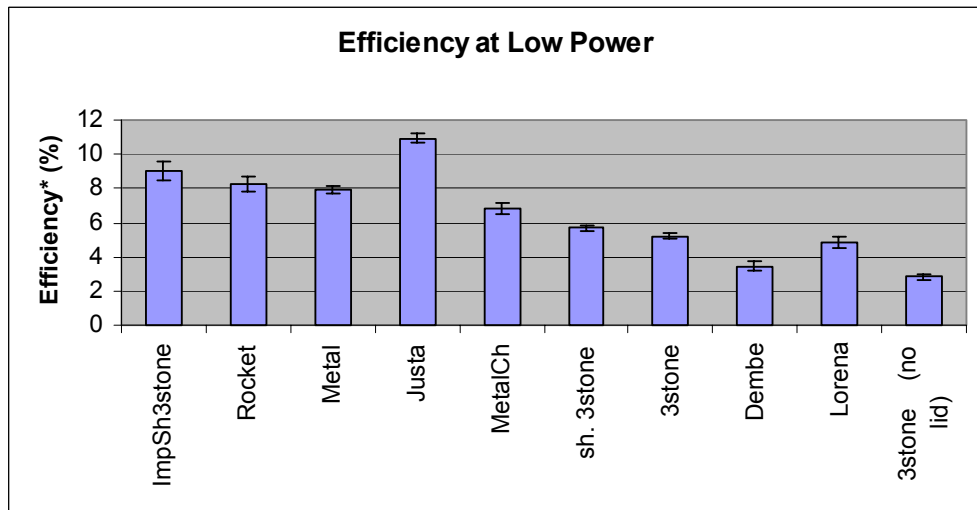

Figure 6-5 Graph to show Efficiencies<sup>10</sup> of Improved Stoves for Simmer Test



The improved Shielded 3-stone, Rocket and Metal Stove all give good savings, at around 40%. However, when the energy given to the second Justa pot is taken into account, it gives an efficiency higher than any other stove. In addition the water in the second pot reached an average of around 85°C, higher than the same figure for the Lorena. If the power to the second Lorena pot is sufficient (it is widely used) the Justa second pot should also be acceptable. The metal stove can also offer significant savings even with a chimney attached.

<sup>10</sup> These efficiencies do not account for steam production, and should not be compared to those given for high-power tests. They are given here purely because fuel consumption figures cannot account for the extra work done by two-pot stoves. Efficiency figures are usually calculated to include steam production.

## 6.3 Meal Cooking

The meal cooking test was conducted as before (see section 4.3.1). A meal of matoke (cooking bananas) and G-nut (peanut) sauce was prepared by a Ugandan housewife. The energy required to prepare such a meal is shown in Figure 6-6. The following graph, Figure 6-7, shows the data expressed as savings.

Figure 6-6 Graph to Show Fuel Used in Cooking Test

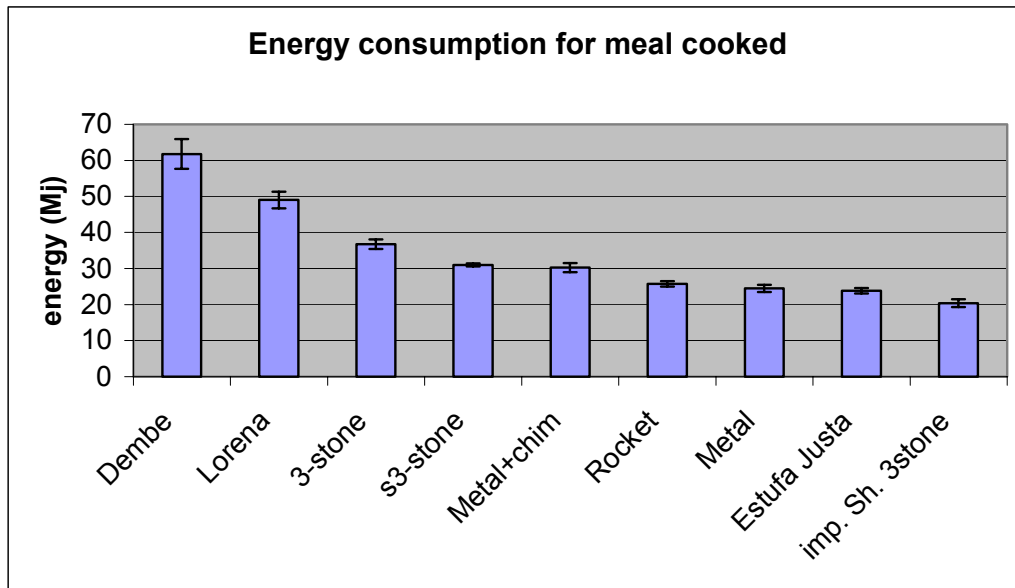
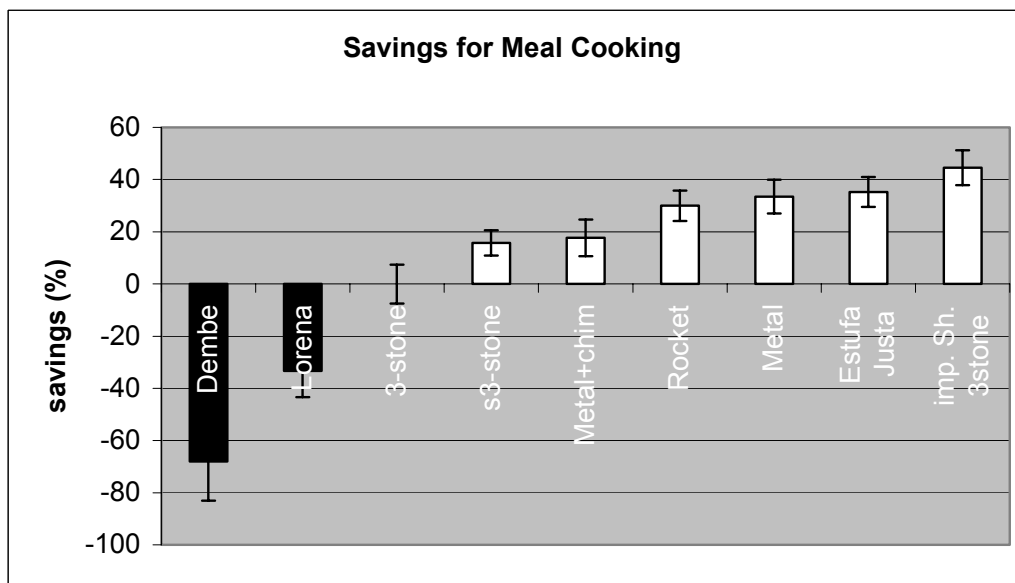

Figure 6-7 Graph to Show Savings for Cooking Test



The improved shielded 3-stone fire has again produced a considerable fuel saving. The Estufa Justa and metal stoves also save above 30%, with the rocket stove not

far below. As shown previously, the addition of a chimney to the metal stove increases fuel consumption, but some savings can still be achieved.

Although the previous experiments have indicated that the power given to the second Justa pot is sufficient (comparable to the Lorena's) it was discovered that when cooking, the second pot, containing sauce, tended to boil on one side only. The cook considered this to be unsatisfactory. Clearly the heat transfer mechanism should be altered to allow the half of the pot nearest the chimney to achieve higher temperatures.

The times taken to cook the meal are shown in Figure 6-8

Figure 6-8 Graph to Show Times Taken for Meal Cooking

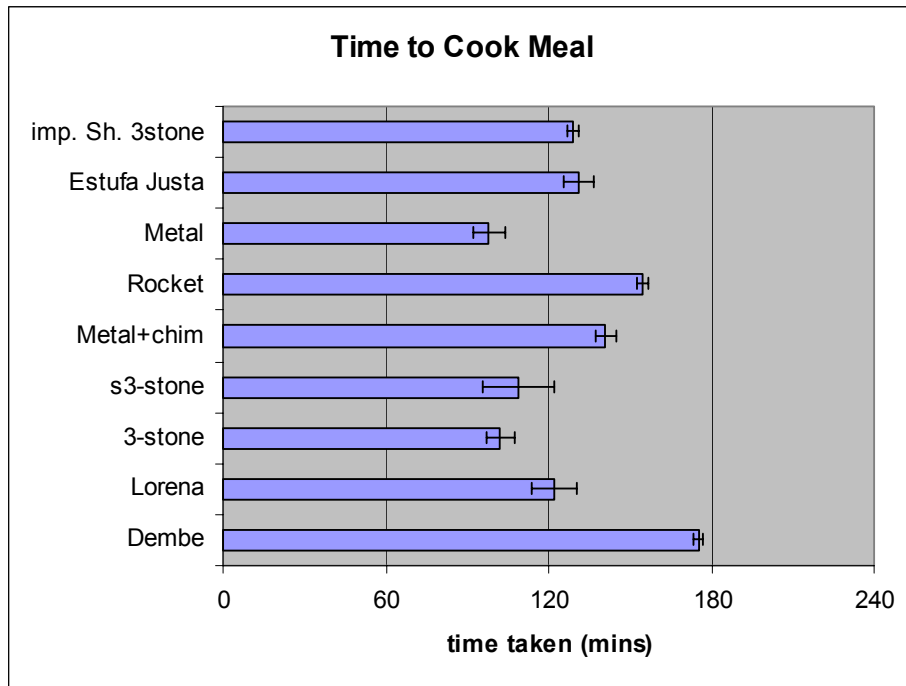

Cooking times are generally similar, clustering around the two-hour mark. However, the rocket's low power is reflected in a longer cooking time. The new stoves do not show faster cooking times than the original designs tested, and their power is generally no higher, despite the increased efficiency demonstrated. Except in rare cases where very high power cooking is required, the power provided by the three-stone fire is sufficient – for this meal the cook does not require full power except at the very start. Thus, provided a stove can deliver the approximately 800W desired, there is no real advantage in increasing power output. However, the Dembe and rocket stove have failed to produce the ideal power to cook the meal, resulting in extended cooking times and therefore more potential for heat loss and wasted energy.



## 6.4 Summary of Results

### Test 1:

The rocket stove, Estufa Justa, metal stove and improved shielded 3-stone fire all give efficiencies of above 20% at high power, with the metal stove and chimney a little lower, but still an improvement on the open three-stone fire. The relatively low power output for the rocket may be addressed by shortening the internal chimney. The Estufa Justa delivered an inadequate level of power to the second pot, widening the airflow gaps proved an effective solution.

### Test 2:

The five stoves above performed well, all giving significant savings on a three-stone fire. When both pots are accounted for, the Estufa Justa gave the best efficiency, with the improved shielded 3-stone in second place.

### Test 3:

The improved shielded 3-stone fire gave the largest savings at 43% .The Estufa Justa and metal stoves also gave good savings, but the rocket's lower power resulted in slightly extended cooking times. The metal stove with chimney gave some savings.

## 7 Benefit Assessment

This report has covered tests on ten stove types. Results have shown that several of these offer user benefits when compared to a three-stone fire. Key benefits are outlined in the table below, although at a later stage a user survey is necessary to determine perceived benefits.

It has been found that a crucial factor for successful stoves programmes is the time required for the stove to save the equivalent of money spent on its purchase (World Bank 1994). A stove requiring above 1 to 3 months to achieve this has a reduced chance of success. Figures given in the table are based on the test 3 meal cooked twice a day, and assuming that a 7kg bundle of wood costs 700Ush (in Kampala). In reality most families will cook larger meals than the one tested, and will thus save faster. It is impossible to give a lifespan for the improved stoves, since the test period has been relatively short.

Stoves requiring extra effort to operate are also less successful, it is not clear whether the reduced entrance size of the rocket designs will necessitate chopping, this will obviously depend on the thickness of available wood. It may be necessary to increase entrance sizes, reducing efficiency. Again, user feedback is essential.

Many stoves can claim “smoke removal” as a benefit. However, the method employed by the stove operator involved placing the pot on the stove only after it was well lit. Thus during the lighting phase smoke escapes into the room. Smoke may also enter the room if wind is forced down the chimney, especially from the Lorena and Estufa Justa. When the fire is low, smoke will occasionally escape from the door of the metal stove with a chimney, the door size should be reduced. If the sealing rings around the sunken pots are not well made, wisps of smoke can escape from around the pot sides, but the pull of air from the chimney tends to reduce this problem. All the stoves with chimneys do remove the majority of smoke, however and this is a great advantage.

Stove	Advantages	Disadvantages	Approx Price (Ush)/ US	Cost Return months
3-stone	Fairly efficient if used well. Flexible (size of pot, grilling etc) Social focal point No maintenance Gives light and space heating Culturally acceptable	Does not remove smoke Unsafe – fire risk, children	0 -	-
Lorena	Removes smoke Materials locally available. Two pots Safe -no hot surfaces Good reputation	Inefficient	10 000-30 000/	no
Dembe	Removes smoke Materials locally available. Safe -no hot surfaces Flexible pot size	Very slow Inefficient	8000-25 000/ 2.00	no
Shielded 3-stone	Some fuel saving Materials locally available.	Does not remove smoke and not portable	5000-10 000/ 0.60	3
Metal stove	Efficient Portable Looks similar to traditional Sigiri	Does not remove smoke Hot sides Inflexible pot size	5000/ 2.40	1.5
Metal stove with chimney	Fairly efficient Removes smoke Looks similar to traditional stove	Hot sides Inflexible pot size	8000/ 4.00	4
Rocket Stove	Efficient Removes smoke 1 or 2 pots	Must be made professionally Inflexible pot sizes Unfamiliar design Fairly low power	25 000 –30000 /12.00	7

Estufa Justa ("Lorena 2")	Efficient Removes smoke 2 pots Looks like familiar Lorena	Materials not available everywhere, Promoters must be trained	20 000/ 7.00	5
Improved Shielded 3- stone	Very efficient Simple to build	Does not remove smoke, vermiculite only available in certain areas	8000- 12 000 2.40	2

## 8 Conclusions

- The effect of stoves on overall efficiency is less significant than the use of a lid. Since the majority of Ugandans do not use a lid when cooking, the author suggests that dissemination of lids (and information) should be considered to be at least as important as stove dissemination. It may well be that these two objectives are best achieved simultaneously, but promoters should be clear on their relative importance.
- The Lorena and Dembe stoves do not give fuel savings compared to an open fire in sheltered conditions, in reality they use considerably more fuel to perform all the tasks required of them in these tests. Their high mass body conducts heat away from the fire and pot, only a small area of pot is exposed to heat, and the chimney, particularly in the Dembe, sweeps heat out of the stove too quickly.
- If the Lorena and Dembe are to be promoted, it should not be on the basis of fuel savings, since their use would actually result in increased wood consumption.
- The Dembe is much slower than other stoves tested. A woman operating it would have to not only spend time collecting the extra wood needed to cook, but would also have to wait around an hour longer every time she cooked a meal, probably at least two hours a day.
- The simple metal stove can offer significant savings compared to an open fire, both in the standard 90 minute simmering test, and when cooking a traditional Ugandan meal, it can also offer a small time saving.
- The metal stove would seem to be a possible candidate for promotion in Uganda, providing it is culturally acceptable. It can be produced cheaply from scrap metal, and is light so transportation should be possible. However it must fit the pot used, so, if tailor-made stoves are impractical, a range of sizes must be available, to fit common pot sizes. The stove's disadvantage is that smoke is not removed. However, it is extremely portable and should be used outside when possible. The addition of a chimney is probably worth the few percent loss in efficiency.
- An even better efficiency can be achieved with the rocket stove, and the Estufa Justa. Both stoves also remove smoke. The Estufa Justa would be a good replacement for the Lorena; it looks very similar and could benefit from the Lorena's (undeserved) good reputation. However, the rocket stove's power output should be improved to make it an attractive

alternative, and the power distribution in the Estufa Justa could be adjusted in favour of the second pot.

- The improved shielded 3-stone fire has given a very good efficiency, it should be cheap and simple to build. It would be best used outside to remove smoke, but protected from rain. Used inside it should produce less smoke than a 3-stone fire.
- High power stoves such as the metal stove would be particularly effective if used in conjunction with a hay box cooker (for long, slow-cooking meals, not matoke).
- It is essential to test stoves intended for promotion, as word of mouth is clearly not a reliable source of information. It is now necessary to urgently review promotion programmes to avoid wasting effort and money on ineffective strategies.

## 8.1 Suggestions for Next Steps

For many years, NGO's have been promoting Lorena and Dembe stoves in Uganda with the best of intentions. Although these stoves do not deliver the intended fuel savings (or any fuel savings), they have important health benefits for users if a chimney is installed and the stoves are used well. In addition, awareness of the improved stove concept has been created – Very many Kampala residents have positive opinions of the Lorena if questioned. To this extent, what has been done so far should not be considered wasted effort, so long as it can be built upon, taking account of real efficiency results.

All those working with energy issues should be made aware of the performance of the Lorena and Dembe stoves, and the alternatives to them. However, in order not to undermine the confidence of users, and to avoid destroying the good reputation of improved stoves programmes in general, it may be best to emphasise only the “new improvements” to potential users.

NGO's should consider how best to re-structure their stove programmes in order to introduce educational initiatives and stoves which offer genuine fuel savings, while still building on the good reputation of past programmes.

There are five options for fuel saving stoves, as covered in this report.

1. A simple metal cylinder stove, with a skirt around the pot, but no chimney
2. A metal cylinder stove as above, but with a chimney.
3. A rocket stove, incorporating the rocket elbow, insulated firebox and chimney. More research needs to be done to increase power levels.
4. The Estufa Justa stove, introducing the rocket principle into the Lorena
5. An improved shielded 3-stone fire, incorporating the rocket elbow and skirt around the pot

The most efficient of these options has been shown to be the last. Other options may be chosen due to indoor pollution or cost considerations, or cultural preferences.

There are very many factors to consider when selecting a stove. It is probable that a trial and error approach will work best, taking into account the opinion of users, as well as those producing and trading them.

A possible next step would be to arrange meetings to co-ordinate the construction of these stoves within as many NGO'S (or other groups) as possible. They should then allow their members, or preferably users from target areas to use the stoves, and obtain feedback. The comments given by users on areas such as ease of use, appearance or safety should be noted and discussed at subsequent meetings. Changes to the stoves could be proposed, and new prototypes constructed. The stoves should then be tested in laboratory conditions before further dissemination. This iterative process should continue indefinitely, continually improving and updating designs according to user opinion and efficiency requirements.

Results, information and opinions should be shared between as many groups as possible, to avoid unnecessary repetition and permit all groups to work as effectively as possible.

Due to time constraints, this project has not extended to testing a number of possible further improvements to the stoves. These alterations may be a good starting-point for further research;

Rocket stove – Shorten the internal vertical chimney to around 20cm. This should increase heat transfer, but may reduce combustion efficiency. The loss of mass from the stove should also reduce heat lost to the stove body.

Develop a better insulative cheap and strong mixture for linings. Possibly as described in 5.4.

Concerns have been expressed about availability of metal parts. If metal is too expensive, a new design for the Estufa is required, either without sealing rings around the pots, or using ceramic or other material.

Estufa Justa and Improved shielded three-stone stoves could be constructed from Lorena earth/clay for their outer “shell”, a ceramic pot rest supported inside. The inner spaces would be filled with wood ash or pure vermiculite for insulation.

Stoves could be built to fit various pot sizes. It is likely that larger pot sizes will yield better efficiencies. The pots used in these tests may be somewhat smaller than those used in an average family.

The metal stove is a promising option. Small alterations to gap widths, height from grate to pot and chimney diameter may affect efficiency and should be experimented with. Reducing door size should prevent smoke escaping.

Finally, the most important part of any fuel-saving initiative is education on the use of lids and effective cooking practices. All stove promoters, producers, sales people and users must be made aware of this. Primary school science lessons may be one place to start.

## References

- Barnes et al (1994) *What Makes People Cook with Improved Biomass Stoves – A comparative international review of stove papers*. World Bank Technical Paper 242 Energy Series
- DFID (2000) *Poverty reduction aspects of successful improved household stove programmes* DFID KaR R7368
- Forest Department of Uganda, (1993) *Uganda National Biomass Study Report* Kampala, Uganda.
- Gill, J (1985), *Stoves and Deforestation in Developing Countries*
- Mayondo, A. (2001) *Comparison of Brick Lorena Cook stoves and Traditional Stoves in Kitagweda County*
- NEMA, (2001) *State of Environment Report for Uganda*
- Prasad and Verhaart (1983) *Wood Heat for Cooking* Indian Academy of Sciences
- Rouse, J. (1999) *Improved Biomass Cookstove Programmes: Fundamental Criteria for Success*. MA Dissertation, University of Sussex.
- Shanahan (1982) *Stoves and Deforestation in Developing Countries* at [www.odi.org](http://www.odi.org)
- Still, D and Winiarski, L. (2001) *Increasing fuel efficiency and reducing harmful emissions in traditional cooking stoves*. Boiling point magazine, No. 47
- Still, D et al. (1996) *Fuel Efficient Wood Stoves: Efficiency of Combustion, Operator Expertise and Heat Transfer Efficiency*.
- Still, D. *From La Lorena to La Estufa de Dona Justa*. Aprovecho centre web page: [www.efn.org/~apro](http://www.efn.org/~apro)
- Tata (1982) *Wood Conserving Cookstoves : a Design guide* (out of print)
- World Bank (1992) *World Development Report*