

# Laboratory Comparison of the Global-Warming Potential of Six Categories of Biomass Cooking Stoves

Nordica MacCarty, Damon Ogle, Dean Still, Dr. Tami Bond, Christoph Roden, Dr. Bryan Willson  
September 2007



Aprovecho Research Center  
Advanced Studies in Appropriate Technology Laboratory  
P.O. Box 156 Creswell, OR 97426 541-895-5677

## Abstract

Improved cooking stoves have been shown to reduce the amount of fuel used to cook food and the air pollution produced in kitchens. Reducing deforestation and smoke inhalation have been the primary motivating factors for the dissemination of improved cook stoves. Recently, the potential of improved stoves to reduce the effects of biomass combustion on global warming has become a major interest, as well.

Gaseous and particle emissions from six cooking stoves were analyzed: a three-stone fire, a rocket stove, a fan stove, a gasifier stove, a charcoal stove, and a rice-hull burning stove. These stoves were chosen to highlight different methods of combustion. Results indicated a significant difference in emissions between the stoves when the overall climate-forcing effects were calculated as CO<sub>2</sub> equivalents on a 100-year timeframe, known as Global Warming Potential, or GWP.

Overall data showed that as much as a 50% reduction of fuel use, air pollution and GWP can be achieved by three of the wood-burning stoves in comparison to a carefully-tended laboratory three-stone fire. The rocket and fan stoves produced 39%, a gasifier stove 56%, and a charcoal stove 84% of the three stone fire's global warming potential when CO<sub>2</sub> is included. If the fuel is harvested sustainably, then the CO<sub>2</sub> is reabsorbed by the replacement biomass, and can be carbon neutral. In this case, only the products of incomplete combustion (PIC) are considered.

When fuel is harvested sustainably the rocket stove produced 41% of the warming potential of the three stone fire, the gasifier 29%, and the fan stove a remarkable 4%. The burning of charcoal produced 61% more warming emissions than the three stone fire, not counting the energy loss or emissions made when making the charcoal. Products of incomplete combustion (PIC) contributed from 26% to 51% to the overall Global Warming Potential produced by the direct burning natural draft stoves. Estimates of carbon reductions based on fuel use alone may not be accurate if PICs are not measured, especially if the fuel is harvested sustainably.

Measurements were based on the specific emissions, or grams of emissions produced per liter of water boiled and simmered. In this way, heat transfer efficiency is taken into account along with the combustion efficiency. It is important to consider that these results were from laboratory testing field results will differ and be highly variable. The intent of the investigation was to assess the performance of the stoves when operator-influence was minimized in order to better understand the capability of each type of stove technology.

## Introduction

Under the Kyoto Protocol, The Clean Development Mechanism (CDM) is an arrangement allowing industrialized countries with a greenhouse gas reduction commitment to invest in projects that reduce emissions in developing countries. This mechanism provides a lower-cost alternative to more expensive emission reductions in their own countries [16]. The focus of CDM projects typically involve renewable energy projects such as wind, solar, and biomass used for power generation [17].

Cooking stoves are omitted from the CDM-approved projects at this time. Because stoves are used only 10-20% of the day, they are not included in an appropriate power category. There is no carbon allowance for the methane and nitrous oxide emissions from wood used for cooking, thus some of the strongest potential emissions savings are ignored. Recent evidence that identifies wood burning for cooking as a major contributor to Global Warming may strengthen the case to create a household stove category under the CDM [18].

Some of the major greenhouse gases, including carbon dioxide (CO<sub>2</sub>), methane (CH<sub>4</sub>), hydrocarbons, nitrous oxide (N<sub>2</sub>O), carbon monoxide (CO), and oxides of nitrogen (NO<sub>x</sub>), are present in the emissions from biomass cooking stoves. Particulate matter emissions from biomass cooking stoves are also significant and have strong effects on the climate. An August 2007 headline in the online BBC NEWS stated “Clouds of pollution over the Indian Ocean appear to cause as much warming as greenhouse gases released by human activity [19].” These clouds are composed primarily of soot, or black carbon particles. An article found in Scientific American on that day stated “the dominant source for all this black carbon is cooking fires [20].”

The levels of the major green house gases from six stoves were measured at the Aprovecho Research Center using both the ARC laboratory emissions hood and the ARACHNE system developed by the Bond Research Group, and at the Colorado State University Engines and Energy Conversion Laboratory. Gases were measured using FTIR (Fourier Transform Infrared) technology at CSU, and particles were quantified using the light scattering/absorption and filter collection method of the University of Illinois at Urbana Champaign ARACHNE system.

## Background

The manner in which fuel is harvested has a large influence on the climate-change potential when cooking with biomass. If biomass is harvested sustainably, then the CO<sub>2</sub> released in combustion is theoretically reabsorbed by the biomass growing to replace it. If it is not, then the CO<sub>2</sub> released is contributing to the build-up of CO<sub>2</sub> in the atmosphere. The products of incomplete combustion (PICs) such as carbon monoxide, methane, and particulate matter contribute to the changing of the climate in both cases.

Dr. Kirk Smith has pointed out the importance of PICs. “Simple stoves using solid fuels do not merely convert fuel carbon into carbon dioxide (CO<sub>2</sub>). Because of poor combustion conditions, such stoves actually divert a significant portion of the fuel carbon into products of incomplete combustion (PICs), which in general have greater impacts on climate than CO<sub>2</sub>. Eventually most PICs, are oxidized to CO<sub>2</sub>, but in the meantime they have greater global warming potentials than CO<sub>2</sub> by itself. Indeed, if one is going to put carbon gases into the atmosphere, the least damaging from a global warming standpoint is CO<sub>2</sub>, most PICs have a higher impact per carbon atom.” [2].

The non-CO<sub>2</sub> gases contribute to the atmospheric warming in different ways. Some have shorter life spans in the atmosphere but stronger effects. The impact of each gas on the atmosphere in relation to the same mass of CO<sub>2</sub> is defined by its Global Warming Potential, or GWP. The following is a list of gases and descriptions of their relationship to climate change.

**Carbon Dioxide (CO<sub>2</sub>)** – In perfect combustion, emissions from burning fuel would be only Carbon dioxide and water. If biomass was completely combusted, and the fuel was harvested sustainably, cooking with biomass could be a carbon-neutral situation. Unfortunately, as stated, most biomass burning also produces many PICs, which have greater impacts on climate than CO<sub>2</sub>.

**Carbon Monoxide (CO)** – Carbon monoxide is one of the primary products of incomplete combustion. Emissions of carbon monoxide in unimproved wood-burning stoves are frequently as much as 10-15% of the CO<sub>2</sub> emissions, and this figure is even higher for charcoal. Carbon monoxide has a global-warming potential of 3 times that of carbon dioxide [4]. CO generally has a lifetime of several months before it converts to CO<sub>2</sub> by natural atmospheric processes. The GWP of CO results only from its effects on atmospheric chemistry. It reduces the amount of an available radical, •OH, thereby increasing the lifetime of the greenhouse gas, methane.

**Methane (CH<sub>4</sub>)** -- Methane is a relatively potent greenhouse gas. Averaged over 100 years, each kg of CH<sub>4</sub> warms the Earth 21 times as much as the same mass of CO<sub>2</sub>. Methane has an atmospheric lifetime of about 12 years. Methane is a part of the Kyoto Accords and is considered one of the most important greenhouse gases resulting from biomass burning [4].

**Non-Methane Hydrocarbons (NMHC)** – Hydrocarbons are gases consisting primarily of hydrogen, carbon and oxygen. Emissions of unburned hydrocarbons indicate incomplete combustion and the vapors can be harmful if inhaled. Overall, the 100-year GWP of the non-methane hydrocarbons is approximately 12 times that of CO<sub>2</sub>, with climate forcing occurring because of their contribution to ozone formation [5].

**Nitrous Oxide (N<sub>2</sub>O)** – A powerful greenhouse gas, nitrous oxide has an atmospheric lifetime of 120 years and a GWP of 296 over 100 years. N<sub>2</sub>O is also a part of the Primary Kyoto Accords and one of the primary gases considered in inventories of biomass burning [4]. While naturally occurring from bacteria and oceans, the main source of human-produced nitrous oxide seems to be the use of nitrogen fertilizers and animal-waste handling.

**Oxides of Nitrogen (NO<sub>x</sub>)** – NO<sub>x</sub> is a broad term for the various nitrogen oxides produced during combustion when combustion temperatures reach a high enough level to burn some of the nitrogen in the air. NO<sub>x</sub> is an ozone precursor and when dissolved in atmospheric moisture can result in acid rain. Oxides of nitrogen affect atmospheric chemistry in complex ways, including interactions with •OH radicals and contributing to ozone chemistry. They are presently thought to be greenhouse neutral [6].

**Particulate Matter (PM)** – PM is composed of tiny, solid or liquid particles. The effects of inhaling particulate matter have been widely studied in humans and animals. They include asthma, lung cancer, cardiovascular issues, and premature death. By weight, particles can have an extremely strong effect on the atmosphere by absorbing and/or scattering the sun's incoming radiation. Different types of particles have varying levels of scattering vs. absorption, defined by their Single Scattering Albedo (SSA). If the particles have low SSA, they absorb more sunlight and create more warming in the atmosphere. Generally, particles that have low SSA have a higher ratio of elemental to organic carbon in their composition. Though not a part of the Kyoto agreement, the climate forcing effects of the particles emitted from biomass combustion are quite substantial as shown in this study

*Black, Elemental Carbon (EC)* – Elemental, or black carbon particles, is carbon that will not volatilize at a temperature of ~600°C (in an inert environment). EC is produced in flaming fires and is also called soot. It is one of the most important absorbing aerosol species in the atmosphere. Elemental carbon from combustion has a global -warming potential 680 times that of each equivalent mass of CO<sub>2</sub> [7].

*Organic Carbon (OC) and Organic Matter (OM)* – OC and OM are generally produced in smoldering fires. Organic carbon consists of primarily scattering particles/aerosols that can be white to clear to brown. OC contributes to global cooling because it is composed of aerosol particles that reflect sunlight back into space. The pollutants can also become nuclei for cloud droplets, which reflect even more sunlight back into space, but those clouds also trap heat radiated from the earth, so the effects of clouds are complex. In aerosols, organic carbon does not exist in isolation; it is bonded to oxygen and hydrogen. Together, the organic compounds are called *organic matter* (OM). The typical OM to OC ratio is 1.5 to 2.1, but can vary widely. The warming potential of OM was recently estimated as negative 75 CO<sub>2</sub> equivalent for organic matter [15]. Since the time of that estimate, organic carbon from biofuel combustion has been shown to be slightly absorbing, and therefore has a lower GWP. According to the author of the previous work, a likely estimate is now -50. Research is underway to verify that value [6].

## Testing Methods

Six stoves were tested in an effort to examine four common methods of wood combustion: open burning, “rocket”-type combustion, gasification, and forced draft. The “rocket” stove, gasifier, and forced-draft fan stove are considered “improved” stoves. The three-stone fire is a traditional cooking technology. The emissions from a charcoal stove and a rice-hull burning stove were also investigated. All six stoves are shown below:



Three-Stone Fire



Rocket Stove with Skirt



Karve Gasifier



Philips Prototype  
Fan Stove



Jiko Charcoal Stove



Mayon Turbo  
Rice -Hull Stove

- Three-Stone Fire – Sticks of wood are burned directly under the pot which was held 22 cm above the testing surface by three bricks. It is estimated that 2.5 billion people worldwide use a three-stone fire or similar traditional method for cooking.
- Household Rocket Stove – A well-insulated rocket stove prototype with a 10 cm diameter and 30 cm tall combustion chamber. The stove was developed by Dr. Larry Winiarski and Aprovecho Research Center, USA. The “rocket stove” technology has been available for 25 years. It is estimated that at least a half million rocket stoves may be in use worldwide.
- Household Karve Gasifier Stove – In this gasifier stove, 5 cm long pieces of wood fill a cylindrical combustion chamber. The batch of wood is top lit. Secondary air passes over the top of the combustion chamber. This stove was recently developed by Dr. A.D. Karve, Appropriate Rural Technology Institute, India.

- Philips Prototype Fan Stove – Forced-air jets provide better mixing of the flame, gases, and air. 5 cm long pieces of wood are fed into the combustion chamber in a space between the top of the stove and the pot. The fan stove was run at a constant 15 VDC for both boil and simmer. The stove is being developed by The Philips Company in the Netherlands.
- Jiko Type Charcoal Stove – Pieces of charcoal are combusted in a bowl shaped combustion chamber. Holes allow air to enter the combustion zone from underneath the charcoal. Note that the data presented in this report does not count the energy lost or emissions produced when wood is made into charcoal. The Jiko type stove was disseminated by Enterprise Works/VITA in Uganda. Since 1982, approximately 200,000 of the Jikos have been distributed in Ghana.
- Mayon Turbo Rice-Hull Stove – Rice hulls fall into a combustion chamber from a truncated conical hamper. Particle emissions were not measured from this stove due to a lack of rice hull fuel during the particle testing series. Developed and disseminated by REAP, Philippines. Over 5,000 stoves have been distributed in the Philippines.

A modified University of California at Berkeley 2003 Water Boiling Test was used to test each stove three times [8]. There were 2.5 L of water used in a standard 3 L pot. Due to time constraints, the hot-start phase of the test was omitted. Also, the water was simmered for 30 rather than 45 minutes.

The open fire and rocket stoves were started with a small amount (10-15g) of newspaper. The fan, gasifier and rice hull stoves were started with wood kindling soaked in charcoal lighter fluid. The charcoal stove was started with lighter fluid. The emissions from these starting aids were negligible. Between the high and low power phases, the fuel was removed from the three stove, rocket, and fan stoves for weighing, sometimes leading to a brief emissions spike that was removed from the calculations.

The fuel used for the wood stoves was 1cm x 2 cm sticks of kiln-dried Douglas fir. The sticks were cut into approximately 5 cm lengths for the fan and gasifier stoves. Moisture content was determined by the oven drying method to be an average of 3.4% on a wet basis [8]. Natural mesquite charcoal was used in the Jiko stove and rice hulls from the Philippines were burned in the Mayon Turbo stove. The moisture content of the rice hulls was 4.0% on a wet basis.

The UCB Water Boiling Test was used in order to combine the stove-emissions measurements with quantifications of the heat transfer efficiency for each stove. It should be noted that the results are from carefully-tended fires in the laboratory with dry fuel. Field results will vary considerably due to operation by cooks, the use of different fuels, pots, fuel moisture contents, cooking practices, and quantities of food cooked. The Water Boiling Test minimizes these variables in an attempt to determine the difference between the heat transfer and potential combustion efficiencies of the stoves when operated in a controlled fashion.

## *Gas Analysis*

In July of 2006, Aprovecho mechanical engineers Nordica MacCarty and Damon Ogle traveled to Colorado State University's Engines and Energy Conversion Laboratory in Fort Collins, Colorado. Under the guidance of Dr. Bryan Willson and the Aprovecho team, an emission collection hood was created by students to allow for gas measurements from cooking stoves, using a Fourier-Transform Infrared (FTIR) system for measurement of 23 different species. The hood design was based on the work of Dr. Grant Ballard-Tremeer [3].

In FTIR, IR radiation is passed through a sample of gas. Some of this light is transmitted through the sample while the rest is absorbed, producing a spectrum. Because different gasses have a unique combination of atoms, each produces a unique infrared spectrum, or "molecular fingerprint." Through analysis of this spectrum and corresponding intensity, the makeup and concentrations of a sample gas are determined.

Emissions were collected under a typical emissions collection hood in which a constant volume pump draws the flow into an exhaust-collection system. A sample of the exhaust was brought into the FTIR. Unfortunately, there was a technical problem with the measurement of flow through the system. Thus, only ratios of gas concentrations were available for analysis.



CSU Emissions Collection Hood

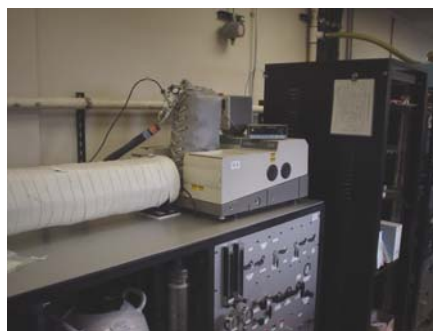

CSU FTIR System

## *Particle Analysis*

Particles were collected at the Aprovecho Research Center using the Laboratory Emissions Collection Hood. The measurement of particulate matter can be extensive, including mass calculations, composition, sizing distribution, and measurement of SSA. The equipment used in these tests included a nephelometer to measure particle scattering, a Particle Soot Absorption Photometer (PSAP) to measure particle absorption in real time, and also a pump-and-filter system to collect and later analyze mass and elemental carbon/organic carbon ratios using a Sunset Laboratories Carbon analyzer. This portable equipment is part of the UIUC ARACHNE system, detailed in the following graphic:

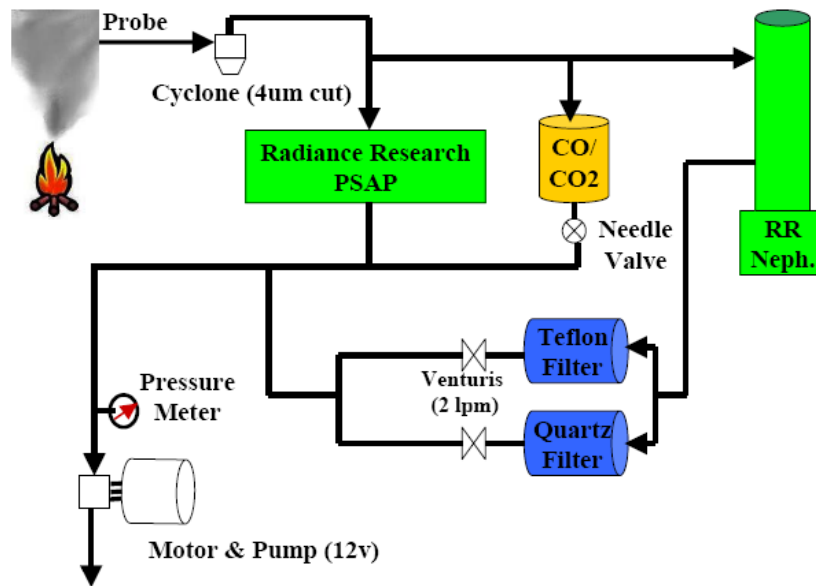

**University of Illinois Urbana  
Champaign ARACHNE System [7]**

Further details about this collection system are available in Christoph Roden's paper entitled "Emission Factors and Real-Time Optical Properties of Particles Emitted from Traditional Wood Burning Cook Stoves." [7]

The particles collected on filters during the tests were analyzed for composition by the Bond Research Group at the University of Illinois laboratory. Organic and elemental carbon composition was measured by a Sunset Laboratories Carbon analyzer. Organic matter was estimated by multiplying the organic carbon by 1.9 as recommended by Christoph Roden. In his recent article he states, "The total mass associated with carbonaceous aerosols, defined as organic matter plus EC, is estimated from the EC and OC measurements. Organic matter (OM), or organic carbon plus associated elements, is usually estimated from OC measurements. Typical OM/OC ratios vary between 1.2 and 3.1 depending on the source and age of the aerosol. We use a value of 1.9 suggested for fireplace combustion of pine or oak. The estimated OM + EC emission factor usually agrees well with the PM emission factor." [7,13].



## Results

This presentation will start with the most basic measures of cookstove performance, building up to a summary of the data into overall global warming potential. The results are divided into the following sections:

1. Heat Transfer Efficiency
2. Combustion Efficiency
3. Combining HTE and CE: Emissions per Task Completed
4. Overall Weighted Global Warming Potential

Each chart will show the average of the three Water Boiling tests for gases, and the results from the one Water Boiling test for particulate matter. The data is presented in a step-by-step fashion which culminates in predictions of the total warming potential with all compounding factors included. Variation between the three tests and real-time data are included in the appendix.

### 1. Heat Transfer Efficiency

Investigation of heat transfer efficiency is the first step in quantifying the difference between cooking stoves, since the amount of fuel burned is directly related to the amount of climate and health-harming emissions produced. The following chart shows the time to boil and amount of fuel required to complete the Water Boiling Test cooking task: to bring 2.5 L of water to boil and then simmer the remaining water for 30 minutes. This data was taken during the collection of gases at the CSU laboratory.

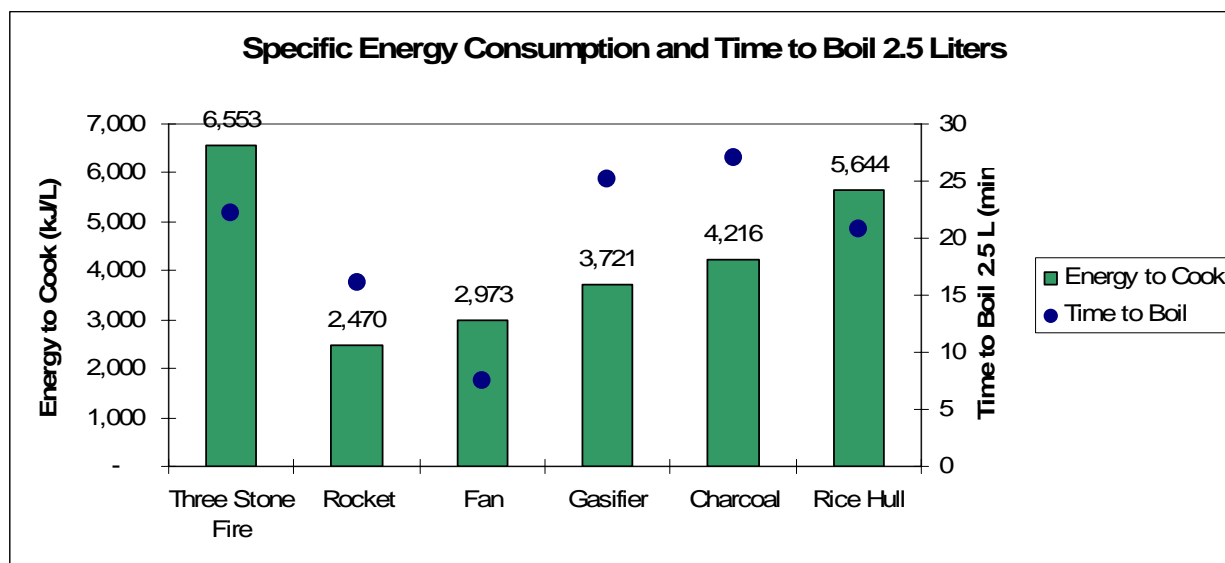

\* This chart does not include the energy to power the fan, running at 1 Watt for 37 minutes, or 2.25 kJ of additional energy input.

As expected, the three-stone fire used the most energy to boil and simmer the water when compared to the three other wood-burning stoves. Time to boil was lower in the fan stove, followed by the rocket stove. Time to boil was similar for the three stone fire, the gasifier, charcoal and rice-hull stoves.

The assumed calorific values for the dry fuels were as follows:

Wood, Douglas fir	20,580 kJ/kg	
Natural Mesquite Charcoal	29,400 kJ/kg	
Rice Hulls	14,000 kJ/kg	[9]

## 2. Combustion Efficiency

For the gaseous emissions, Pollutant/CO<sub>2</sub> ratios are common measures that show the ratio of each Product of Incomplete Combustion to the CO<sub>2</sub> on a percentage basis. Since perfect combustion would yield only carbon dioxide and water, this measure indicates how cleanly the stove is combusting each carbon molecule by either producing CO<sub>2</sub> or alternately producing unburnt hydrocarbons, carbon monoxide and formaldehyde emissions.

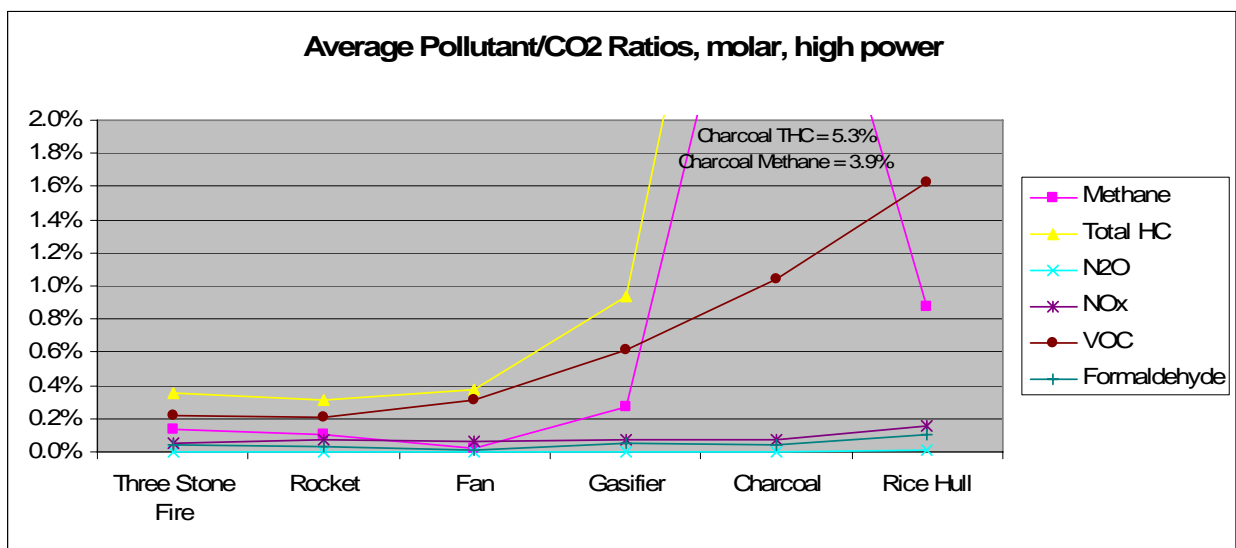

This chart presents the relationship of the non-CO gas emissions. Formaldehyde and nitrogen compounds show the lowest emissions, followed by VOCs, methane, and finally CO.

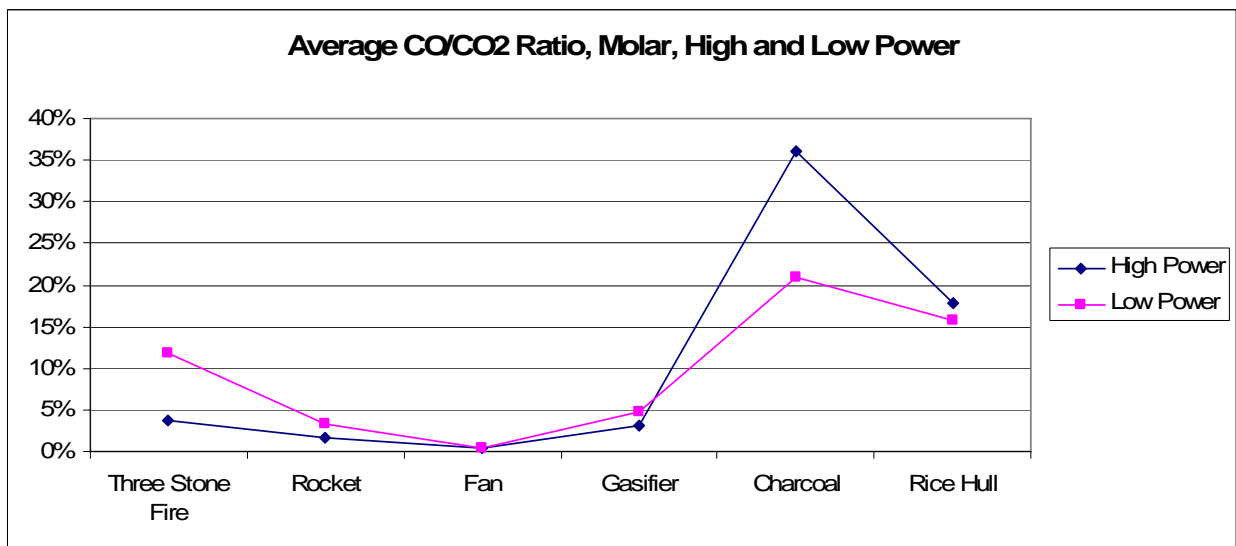

Emissions of CO from the stoves can be roughly 10 times higher than that of hydrocarbons, with the three-stone fire emitting 12% CO in relation to CO<sub>2</sub>. The charcoal and rice hull stoves were even higher. The hot, insulated combustion chamber of the rocket stove assists in the reduction of carbon monoxide. The fan stove creates quite low levels which may be due to the additional mixing that is relatively absent in natural-draft stoves. The charcoal and rice-burning stoves, have higher CO/CO<sub>2</sub> ratios, perhaps because of the lack of flame. As a point of comparison, the South African Bureau of Standards recommends that the CO/CO<sub>2</sub> ratio be 2% or less for paraffin (kerosene) stoves.

It is interesting to note that CO emissions from the three-stone fire, the Rocket stove, and the Gasifier were higher during low-power operation. When more flame is produced, CO can be combusted. During simmering phases, there is often less flame above the char and more CO escapes. On the other hand, charcoal frequently combusts without producing much flame.

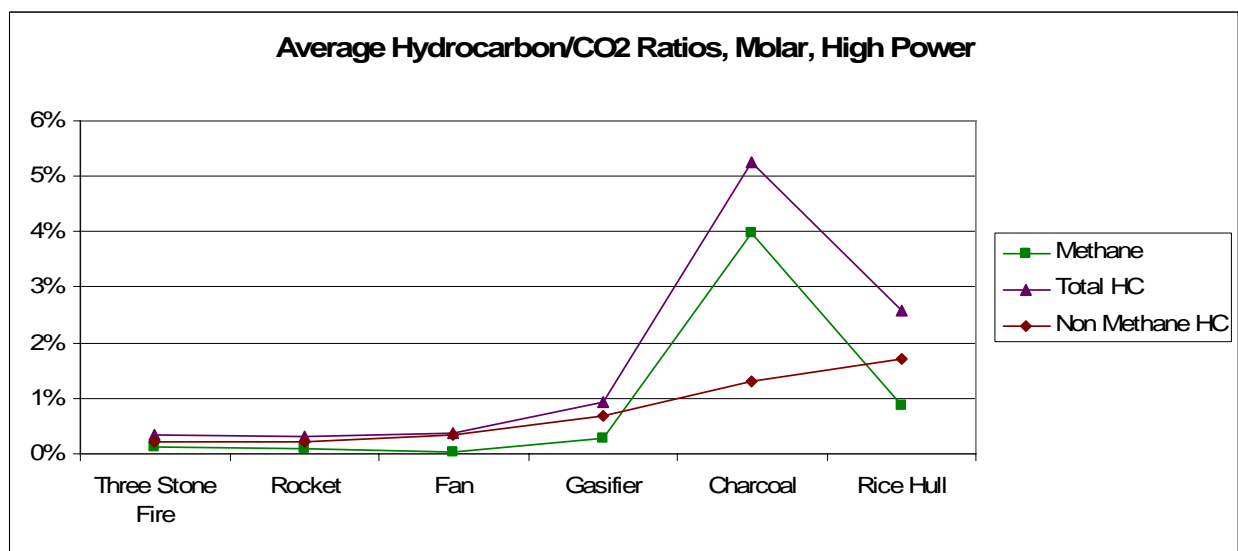

It is interesting that the gasifier produced more hydrocarbons compared to the other wood-burning stoves. The intention of a gasifier is to produce combustible gases through pyrolysis and then burn them by introducing secondary air above the zone of pyrolysis. As can be seen, both the charcoal and rice-hull stoves were also higher emitters of hydrocarbons, again possibly due to lack of flame.

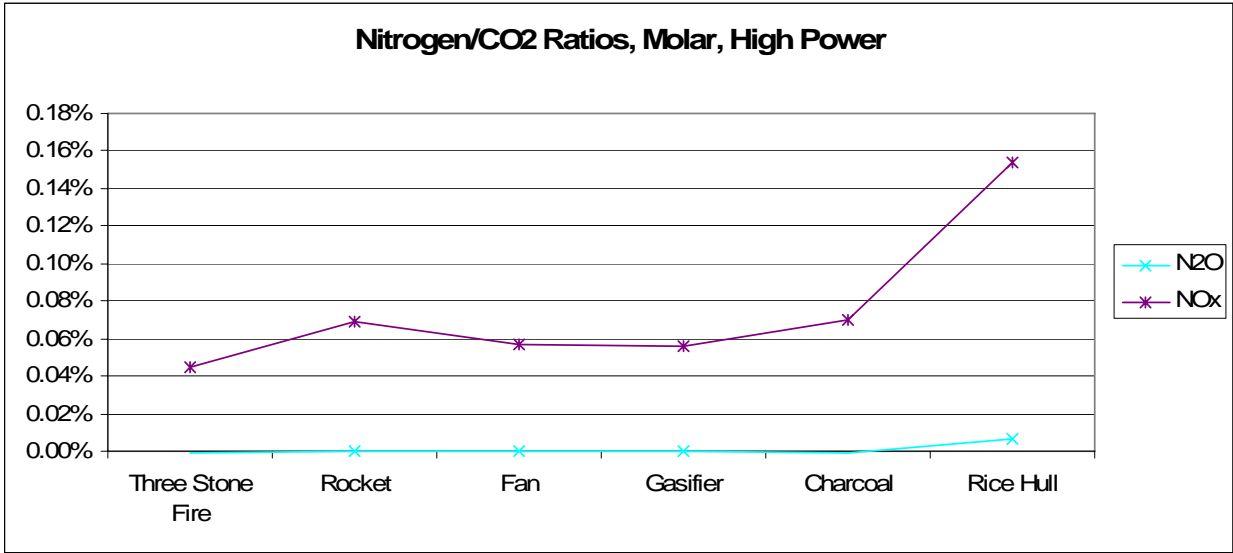

Nitrous Oxide (N<sub>2</sub>O) is an extremely strong global-warming gas, 296 times the affect of CO<sub>2</sub>. Emissions of N<sub>2</sub>O from these biomass-burning stoves were less than .01% of the CO<sub>2</sub>. Emissions of oxides of nitrogen (NO<sub>x</sub>) were slightly higher. The rice-burning stove emits considerably higher amounts of nitrogen-based emissions which may be due in part to the composition of the fuel.

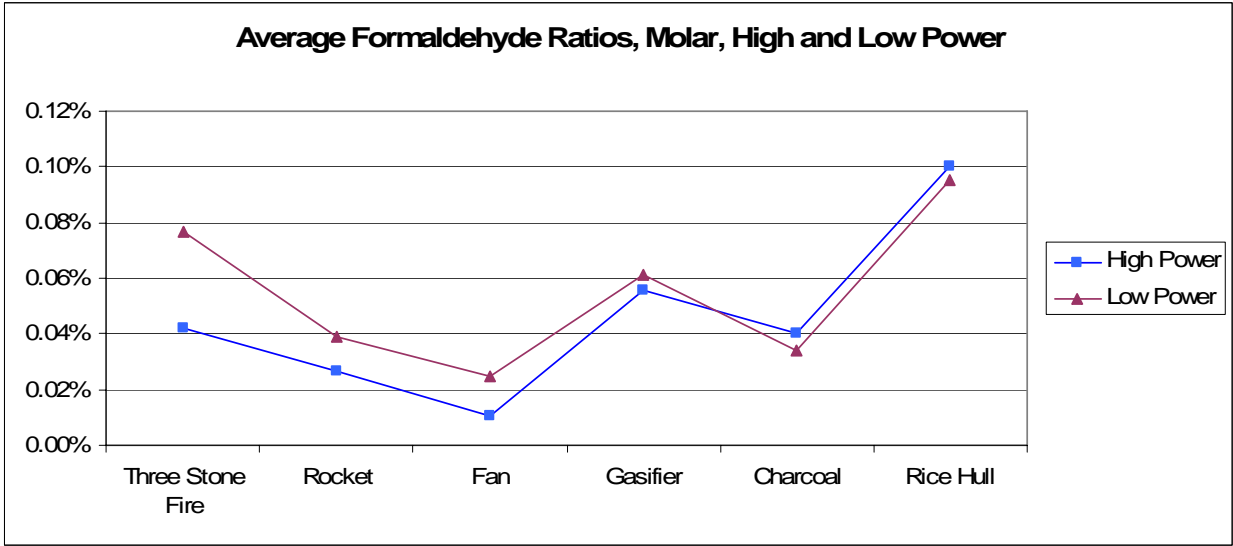

Though not a climate-changing gas, formaldehyde poses health concerns. It is interesting to notice that results are similar to the other emissions, suggesting that formaldehyde may be combusted by the same mechanisms as the other pollutants. The higher temperatures in the rocket combustion chamber, and greater levels of mixing in the fan stove, seem to help to combust the formaldehyde, leading to lower emissions.

The following table presents the results in tabular format. Percentages are relative to CO<sub>2</sub> on a molar basis.

<b>High Power</b>						
	Three					Rice
	Stone Fire	Rocket	Fan	Gasifier	Charcoal	Hull
<b>CO</b>	3.80%	1.67%	0.35%	3.01%	36.0%	17.8%
<b>CH<sub>4</sub></b>	0.13%	0.11%	0.02%	0.27%	3.99%	0.87%
<b>NMHC</b>	0.22%	0.22%	0.36%	0.67%	1.29%	1.71%
<b>N<sub>2</sub>O</b>	0.00%	0.00%	0.00%	0.00%	0.00%	0.01%
<b>Nox</b>	0.01%	0.01%	0.01%	0.01%	0.01%	0.01%
<b>Formaldehyde</b>	0.04%	0.03%	0.01%	0.06%	0.04%	0.10%
<b>Low Power</b>						
	Three					Rice
	Stone Fire	Rocket	Fan	Gasifier	Charcoal	Hull
<b>CO</b>	11.8%	3.2%	0.4%	4.7%	20.9%	15.7%
<b>CH<sub>4</sub></b>	0.29%	0.17%	0.07%	0.42%	0.35%	0.57%
<b>NMHC</b>	0.18%	0.10%	0.08%	0.54%	0.05%	0.85%
<b>N<sub>2</sub>O</b>	0.00%	0.00%	0.00%	0.00%	0.00%	0.01%
<b>Nox</b>	0.07%	0.11%	0.08%	0.06%	0.06%	0.15%
<b>Formaldehyde</b>	0.08%	0.04%	0.02%	0.06%	0.03%	0.10%

For the Particle emissions, the ratios of elemental carbon (EC) and organic matter (OM) may indicate trends in combustion. Since the manner in which the fire is tended (whether smoldering or flaming) can have a significant effect on the type of particles produced, user tendencies should be considered. Local practice, as well as wood species and condition, are also important variables. However, the type of stove also plays a substantial role. For example, there is an inherent difference between a charcoal-making gasifier compared to an open fire due to the nature of combustion.

#### Emission Factors (g/kg) and OCEC Ratios

	Cooling Particles from Smoldering Fire		Warming Particles from Flaming Fire	
	EF OM (g/kg)	%OM	EF EC (g/kg)	%EC
3 Stone	1.45	<b>62%</b>	0.88	<b>38%</b>
Rocket	0.55	<b>32%</b>	1.16	<b>68%</b>
Karve	0.82	<b>74%</b>	0.28	<b>26%</b>
Fan	0.14	<b>71%</b>	0.06	<b>29%</b>
Charcoal	1.54	<b>88%</b>	0.20	<b>12%</b>

\* Particle analysis was not performed on the rice-hull stove due to a lack of rice-hull fuel during the testing series.

The three-stone fire typically consists of a larger bed of charcoal under the flaming fuel, while the rocket stove has a stronger draft and higher temperature, resulting in less charcoal and higher, laminar flame. The rocket stove produced more flame, which created more warming particles. On the other hand, the smoldering gasifier stove created little flame but more charcoal which produced more cooling than warming particles. Finally, charcoal burning produced almost all white particles, which is typical of a smoldering fire.

### 3. Combining HTE and CE: Emissions per Task Completed

Combining the measures of heat transfer and combustion efficiency result in a useful comparison of expected emissions. This method of calculation involves specific emissions, or the total emissions produced per liter of water boiled and simmered.

When the rate of exhaust flow through the emissions hood is not known, the mass of fuel burned can be used to estimate the actual mass of CO<sub>2</sub> produced, using a carbon balance:

$$\frac{\text{Mass CO}_2}{\text{Mass Fuel}} = \frac{\text{g Carbon}}{\text{g Fuel}} * \% \text{ Carbon to CO}_2 * \frac{44 \text{ g CO}_2}{12 \text{ g Carbon}}$$

[7,12,13]

The fraction of Carbon going to CO<sub>2</sub> is estimated based on the emission levels of the products of incomplete combustion, such as carbon monoxide and particles.

Fuel	g Carbon/ g Fuel	% Carbon to CO <sub>2</sub>	Mass CO <sub>2</sub> / Mass Fuel
Douglas Fir	50% [9]	90%	1.7
Charcoal	82% [11]	65%	2.0
Rice Hull	38.4% [10]	90%	1.3

For every gram of wood fuel, approximately 1.7 grams of CO<sub>2</sub> are produced as emissions. The grams of CO<sub>2</sub> are then multiplied by the pollutant/ CO<sub>2</sub> ratio to determine the mass of each pollutant produced. Finally, these masses were normalized based on the starting temperature of the water and divided by the amount of water remaining at the end of each test phase which results in a measure of emissions per task (1 Liter of water boiled and simmered 30 minutes) completed.

Before factoring by global-warming potentials, the following results are the equivalent mass of the gaseous emissions per task completed:

Specific Emissions (g/L)	Three Stone Fire	Rocket	Fan	Gasifier	Charcoal	Rice Hull
CO <sub>2</sub>	536	206	277	356	300	439
Methane	0.6	2.5	0.9	8.4	62.5	10.7
N <sub>2</sub> O	0.0	0.0	0.0	0.0	0.0	7.8
TNMHC	1.4	4.0	4.3	17.9	29.8	28.9
CO	37	11	2	22	215	66
Total	575	223	283	404	608	552

In a similar fashion, the ratios of warming and cooling particles can be applied to the total particles, showing the total mass of each particle type emitted, as shown.

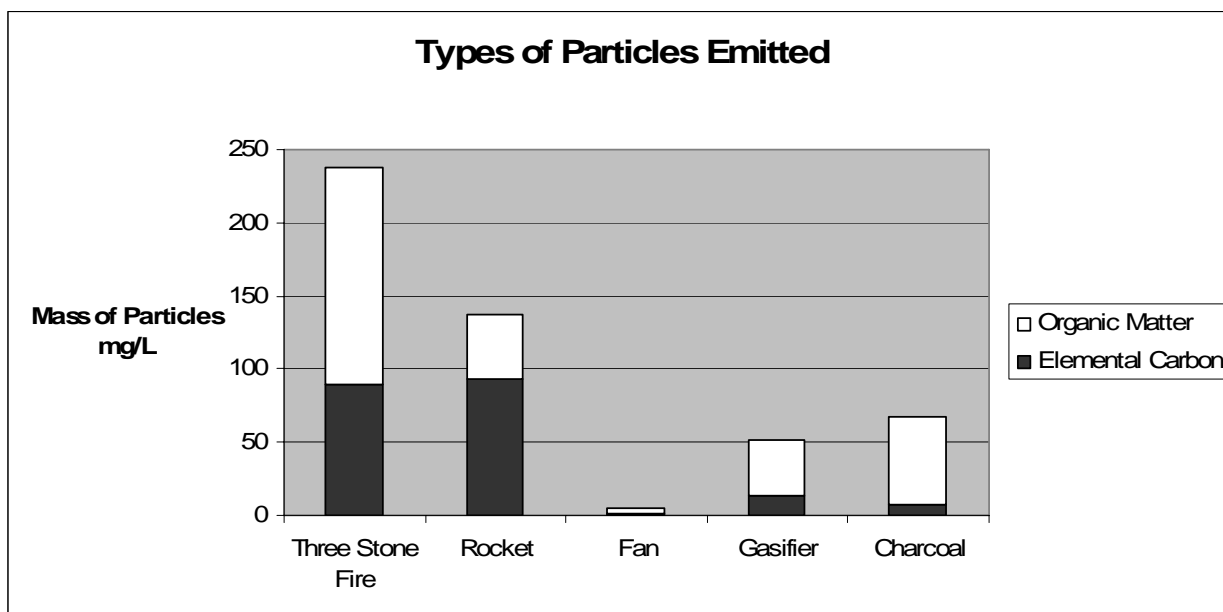

The fan stove was amazingly clean and emitted very low levels of both types of particle matter compared to the other stoves. The gasifier and charcoal stoves made about 1/3 of the PM per liter of water compared to the three-stone fire. The hot flames produced in the vertical combustion chamber of the rocket stove created the same amount of black carbon as the open fire but less organic matter and therefore lower total particle emission.

#### 4. Overall Global Warming Potential

The key greenhouse gases resulting from the combustion of biomass include CO<sub>2</sub>, CO, CH<sub>4</sub>, THC, and N<sub>2</sub>O. The different types of particulate matter influence climate change as well. Each pollutant has a different effect on the atmosphere for a different length of time. In order to better understand how these different effects compare, researchers have developed a Global Warming Potential (GWP) for each of the pollutants. The GWP is a factor that shows how much of a forcing effect a given quantity of that pollutant will have compared to the same mass of CO<sub>2</sub> for a given length of time. On a 100-year timeframe, GWPs are currently accepted as follows:

Emission	Global-Warming Potential, 100-year CO <sub>2</sub> Equivalent	Source
CO <sub>2</sub>	1	IPCC [4]
CO	3	IPCC [4]
CH <sub>4</sub>	21	IPCC [4]
THC	12	Smith [5]
N <sub>2</sub> O	296	IPCC [4]
PM – EC	680	Bond [7]
PM -- OM	-50	Estimate – Bond [6]

(\*It should be noted that the GWP of OC and OM is still uncertain. Research is ongoing to determine the effects of these particles based on their behavior in the atmosphere. Better estimates will likely result from this research. [6])

The mass of each pollutant emitted can be multiplied by its GWP in order to investigate the total carbon commitment for a given combustion method.

When the particles are multiplied by their corresponding GWP, one can see the difference in strength of the warming vs. cooling particles:

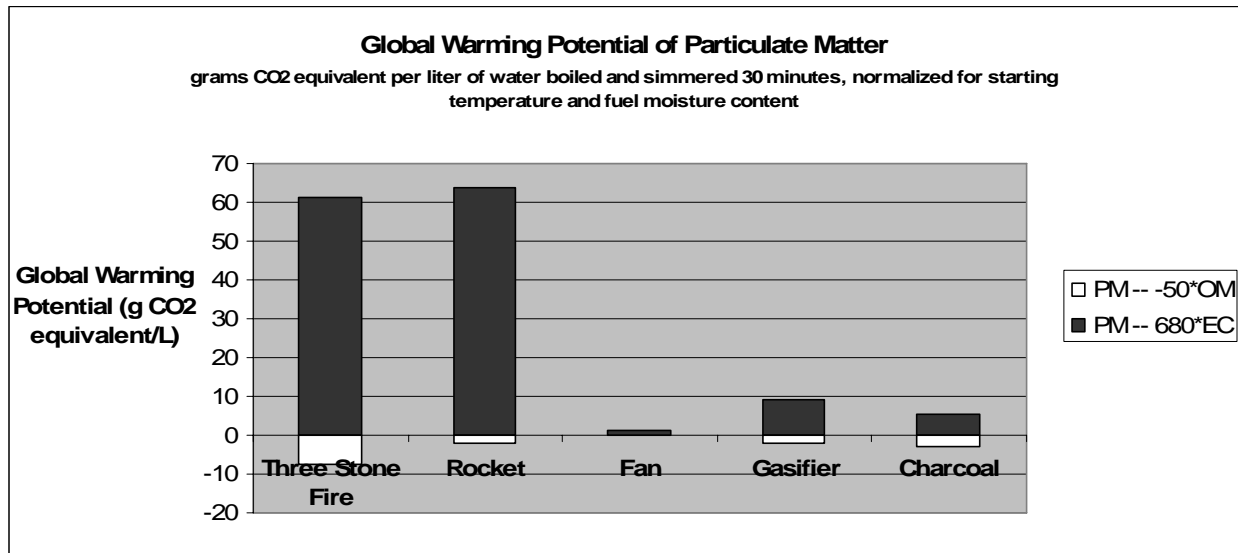

The warming, black carbon particles have a significantly stronger ( $680/50 = 14$  times stronger) effect than the organic (cooling) particles. The rocket stove produced about 50% less total particles than the open fire, but since a higher fraction was black, the warming potential of the rocket stove, due to particles alone, is similar to the open fire. Due to the large difference, it is nearly impossible for the cooling particles to overpower the warming ones, even in purely smoldering fires.

Finally, when GWP is also applied to the gases and all emissions are combined onto the same scale as grams of CO<sub>2</sub> equivalent, the following relationships between stoves and emissions are seen:



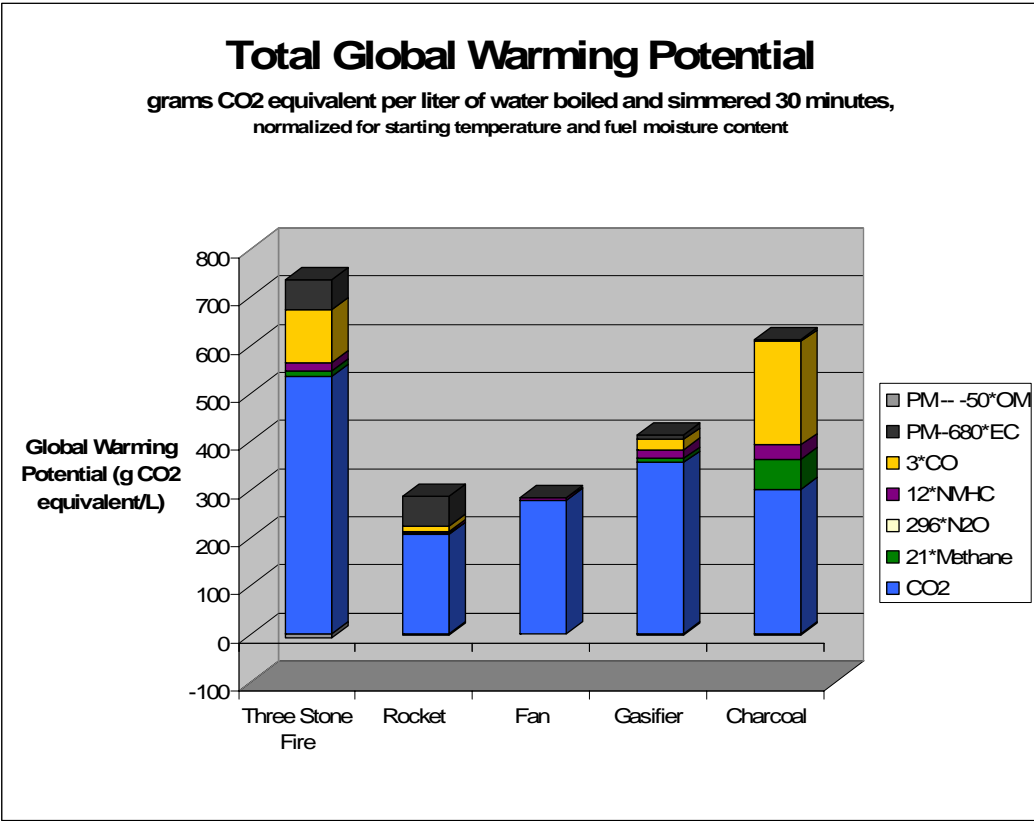

Alternately, since CO<sub>2</sub> emissions from biomass burning are often considered to be greenhouse-neutral, the following chart shows the warming potential of the PICs only:

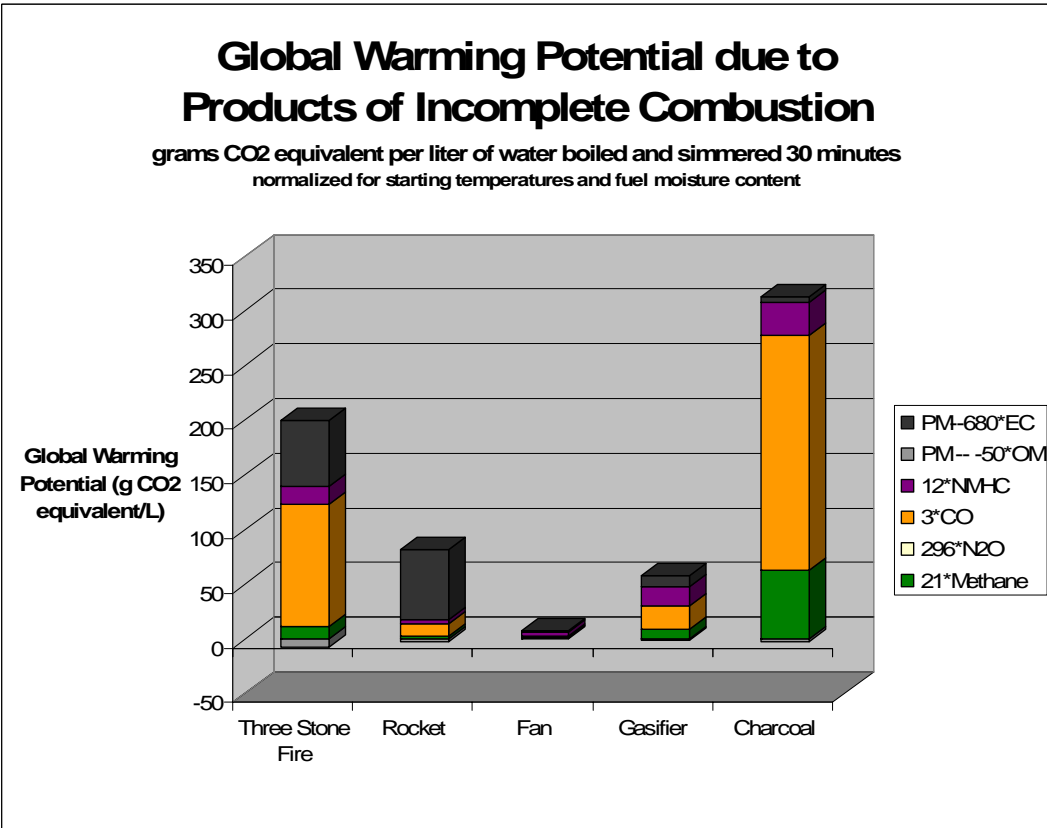

	Three Stone Fire	Rocket	Fan	Gasifier	Charcoal
CO <sub>2</sub> (g/L)	536	206	277	356	300
GWP of non-CO <sub>2</sub> gases (g/L)	139	18	7	48	307
GWP of Particles	54	61	1	7	2
GWP of Total PICs (g/L)	193	79	8	55	310
% of Three Stone Fire, PIC Only	<b>100%</b>	<b>41%</b>	<b>4%</b>	<b>29%</b>	<b>161%</b>
Total GWP (g/L)	729	285	284	411	610
% of Three Stone Fire, PIC +CO <sub>2</sub>	<b>100%</b>	<b>39%</b>	<b>39%</b>	<b>56%</b>	<b>84%</b>
PIC/Total GWP	26%	28%	3%	13%	51%

It is also interesting that the PICs contribute significantly to the total warming potential of most stove types.

## Discussion

In these laboratory tests, several improved biomass stoves (the rocket stove, fan stove, and gasifier stove) displayed substantially reduced global-warming potentials compared to the three-stone fire. Whether the biomass is raised sustainably or not has a large effect on the climate-change effects of the stoves. When fuel is harvested sustainably, and CO<sub>2</sub> is then removed from the equation, the fan stove (which produced much less particulate matter) far outperformed the rocket and gasifier stoves. If wood is not harvested sustainably, and the CO<sub>2</sub> adds to climate change, the fan stove and rocket stove have approximately equal effects, which is due to the lower fuel use in the rocket stove. When CO<sub>2</sub> is counted, reduced fuel use and improved heat transfer can significantly decrease the global warming potential.

The products of incomplete combustion (PIC) contribute 26% to the overall GWP of the open fire, 28% of the rocket stove, and 51% of the charcoal stove. This suggests that estimates of carbon reductions based on fuel use alone may not be accurate.

Further field studies will be necessary to quantify the carbon savings from the use of specific stoves. Laboratory data can identify which stove types look promising. However, follow up studies in the field need to be conducted to quantify the levels of emissions found in the real-world. A key intention of this study was to investigate how GWP studies can best be done in the field.

Recommendations for future field studies include:

- For ECOC particle analysis, real-time measurements with a PSAP do not seem to be necessary. An inexpensive filter system can suffice, reducing the cost and technical know-how required to conduct measurements. Subsequent filter analysis at a high-tech laboratory should be reliable.

- Similarly, real-time measurements of the gaseous emissions may not be necessary. A simple Tedlar bag collection system could be preferable in the field, with bag samples sent to a laboratory for analysis.
- Although N<sub>2</sub>O is a strong climate-forcing constituent, emissions from the wood- and charcoal-burning stoves were very low, contributing less than 1% to the overall warming potentials. Since measurement of this gas is the most difficult, it may not be necessary to include in field evaluations.
- The emissions collection hood system was effective. When a portable emissions hood, available from Aprovecho, is fitted with a filter and bag sampling system, reliable field data can be generated for a low cost and with minimal “expert” involvement.
- It is hoped that once a significant amount of field studies have been completed, an expected relationship may be established between methane and NMHC to CO<sub>2</sub> for differing combustion types and fuels. If this is the case, field measurements may be further simplified.

Both burning wood, charcoal, and rice husks and using different combustion methods have been found to create very different patterns of emissions. The data presented suggests that there are stoves that can be designed to successfully 1.) Reduce the fuel used to cook, 2.) Reduce health damaging emissions, and 3.) Address climate change.

## Acknowledgements

Many thanks to....

*University of Illinois – Urbana/Champaign -- Bond Research Group*  
Christoph Roden and Dr. Tami Bond

*Colorado State University Engines & Energy Conversion Lab*  
Dr. Bryan Willson, and students Peter Letvin, Morgan DeFoort, Roger Nasci, Elisa Guzman,  
Christian L'Orange

Participants at Summer Stoves Camp 2006

Funding for this study was provided by Shell Foundation, with thanks to Ms. Caroline Okwiri

## References

[1] T. C. Bond and H. Sun, CAN REDUCING BLACK CARBON EMISSIONS COUNTERACT GLOBAL WARMING?, *Environmental Science and Technology*, 39, 5921-5926, 2005

[2] Kirk R. Smith, R. Uma, V.V.N. Kishore, Junfeng Zhang, V. Joshi, and M.A.K. Khalil, GREENHOUSE IMPLICATIONS OF HOUSEHOLD STOVES: An Analysis for India, *Annual Review of Energy and Environment* 2000. 25:741–63

[3] Ballard-Tremeer Grant, EMISSIONS OF RURAL WOOD-BURNING COOKING DEVICES, PhD thesis, Faculty of Engineering, University of the Witwatersrand, Johannesburg, 1997

[4] International Panel on Climate Change, "CLIMATE CHANGE 2001: WORKING GROUP I: THE SCIENTIFIC BASIS", Section 4, Table 6.7, IPCC 2007

[5] Rufus D. Edwards and Kirk R. Smith, Carbon Balances, Global Warming Commitments, and Health Implications of Avoidable Emissions from Residential Energy Use in China: Evidence from an Emissions Database,  
[http://www.giss.nasa.gov/meetings/pollution2002/d3\\_edwards.html](http://www.giss.nasa.gov/meetings/pollution2002/d3_edwards.html)

[6] Bond, Tami, Private Conversation. April 19<sup>th</sup>, 2007.

[7] Roden, Christoph A. and Bond, Tami C, EMISSION FACTORS AND REAL-TIME OPTICAL PROPERTIES OF PARTICLES EMITTED FROM TRADITIONAL WOOD BURNING COOKSTOVES, *Environmental Science and Technology*. 2006, 40, 6750-6757

[8] Bailis, Ogle, MacCarty, Still, THE WATER BOILING TEST (WBT), Household Energy and Health Programme, Shell Foundation. 2003-2007.

[9] REGIONAL WOOD ENERGY DEVELOPMENT PROGRAMME IN ASIA  
GCP/RAS/154/NET, Energy and Environment Basics, FOOD AND AGRICULTURE ORGANIZATION OF THE UNITED NATIONS, Technology and Development Group  
University of Twente, Netherlands, Bangkok, July 1997, <http://www.rwedp.org/acrobat/rm29.pdf>

[10] Strehler and Stutzle, BIOMASS RESIDUES, in Biomass, Hall and Overend (eds), 1987

[11] Omar Campos Ferreira, CARBON CONTENT IN BIOMASS FUEL, *Economy and Energy*, Aug-Sept, 2006. [http://ecen.com/eee57/eee57e/carbon\\_content\\_in\\_biomass\\_fuel.htm](http://ecen.com/eee57/eee57e/carbon_content_in_biomass_fuel.htm)

[12] Zhang, J.; Smith, K. R.; Ma, Y.; Ye, S.; Jiang, F.; Qi, W.; Liu, P.; Khalil, M. A. K.; Rasmussen, R. A.; Thorndeloe, S. A. GREENHOUSE GASES AND OTHER AIRBORNE POLLUTANTS FROM HOUSEHOLD STOVES IN CHINA: A DATABASE FOR EMISSION FACTORS. *Atmos. Environ.* **2000**, 34, 4537-4549.

[13] Smith, K. R.; Khalil, M. A. K.; Rasmussen, R. A.; Thorndeloe, S.A.; Manegdeg, F.; Apte, M. GREENHOUSE GASES FROM BIOMASS AND FOSSIL FUEL STOVES IN DEVELOPING COUNTRIES: A MANILA PILOT STUDY. *Chemosphere* **1993**, 26, 479-505.

[14] Turpin, B. J.; Lim, H.-J. SPECIES CONTRIBUTIONS TO PM<sub>2.5</sub> MASS CONCENTRATIONS: REVISITING COMMON ASSUMPTIONS FOR ESTIMATING ORGANIC MASS. *Aerosol Science and Technology*. 2001, 35, 602-610.

[15] Bond, Tami; Venkataraman, Chandra; Masera, Omar. GLOBAL ATMOSPHERIC IMPACTS OF RESIDENTIAL FUELS. *Energy for Sustainable Development*, Volume VIII, Issue No.3, September 2004, pages 20-32.

[16] United Nations Framework Convention on Climate Change (UNFCCC) website:  
[http://unfccc.int/kyoto\\_protocol/mechanisms/clean\\_development\\_mechanism/items/2718.php](http://unfccc.int/kyoto_protocol/mechanisms/clean_development_mechanism/items/2718.php)

[17] United Nations Framework Convention on Climate Change (UNFCCC) CDM website:  
<http://cdm.unfccc.int/index.html>

[18] Samson, Roger. "GREENHOUSE GAS EMISSIONS." Presentation at the Partnership for Clean Indoor Air Conference in Bangalore, India, March 10-13, 2007.

[19] BBC News. "ASIA'S BROWN CLOUDS 'WARM PLANET'." August 1<sup>st</sup>, 2007

[20] Biello, David. "Brown Haze from Cooking Fires Cooking Earth, Too." *Scientific American.com*. August 1<sup>st</sup>, 2007.

Appendix 1. Sample Real-Time Emissions Data

It is interesting to investigate the real-time behavior of emissions during a test. Real time observation can profile how the levels of gases rise and fall as fire conditions change. The following graph shows differences between high and low power performance in the three stone fire.

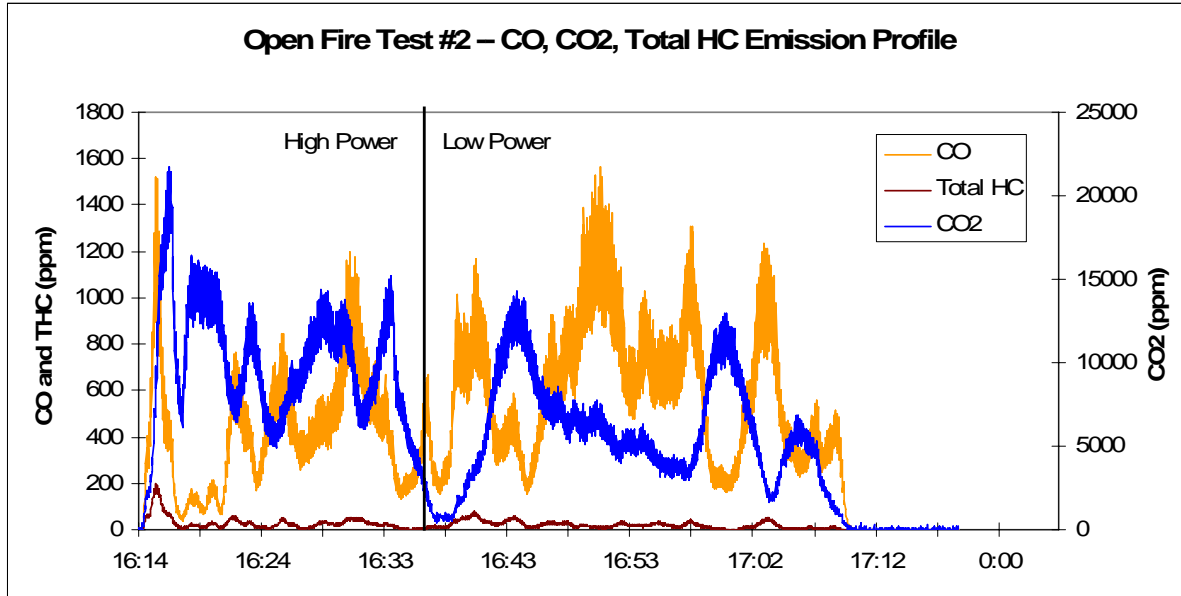

The challenge of maintaining a steady state in the three stone fire can be seen in the highly variable emissions of CO and CO<sub>2</sub>. Since CO<sub>2</sub> represents firepower, it can be seen that the amount of burning fuel varies considerably. Concentrations of CO in the flue gas average at about 600 ppm during high power, increasing to about 800 ppm during low power, when more coals are present. Levels of unburned hydrocarbons are also present at about an average of 50 ppm.

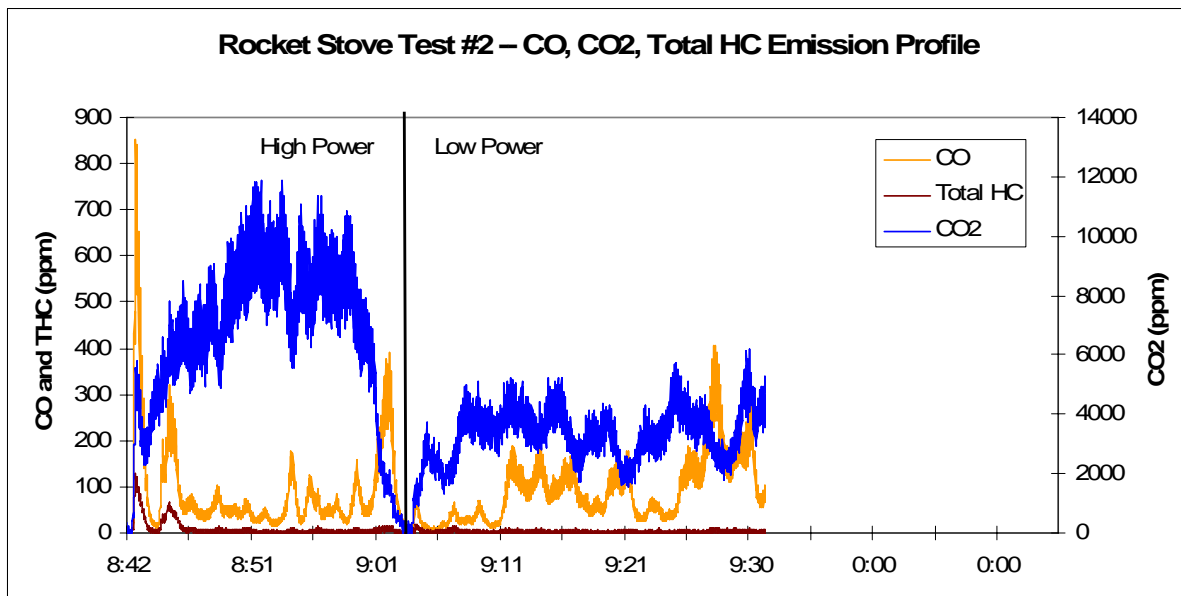

The firepower of the rocket stove is more stable than that of the open fire. Levels of CO remain between 20 and 100 ppm for high power (except during lighting), and are higher for low power,

when less fuel is burning but heat is produced by the charcoal. Emissions of hydrocarbons are negligible for both high and low power once the fire is established.

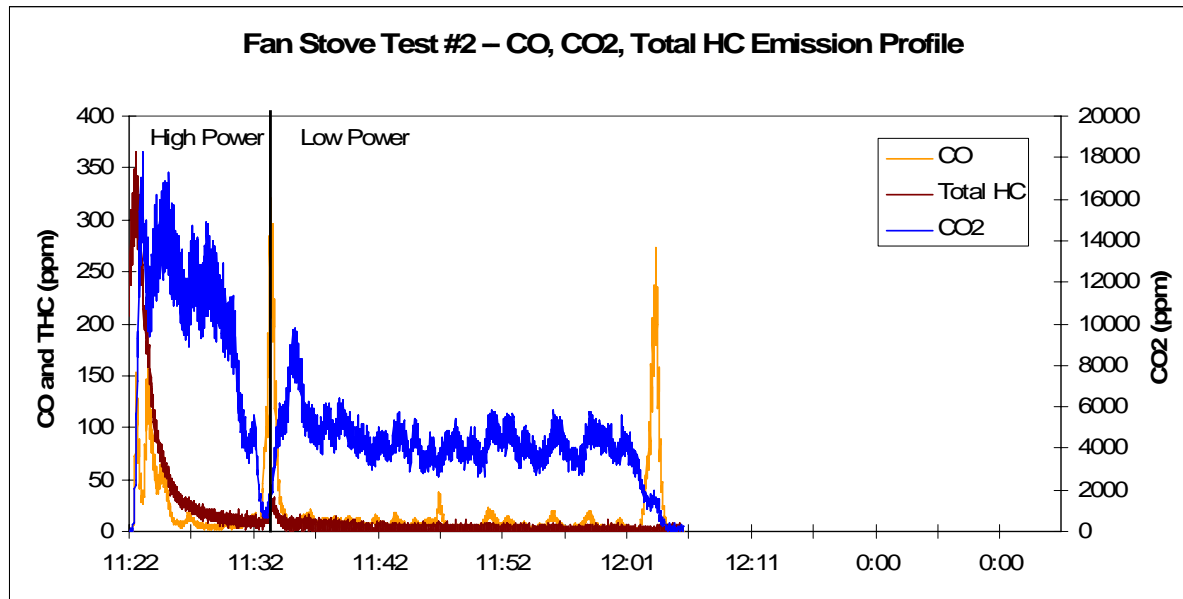

Firepower in the fan stove is very steady. Notice that both CO and HC drop to very low levels once the fire is established in the fan stove. The peaks of CO during the middle and end of the test are caused by removal of the wood in the stove for weighing between boil and simmer, as required by the testing protocol.

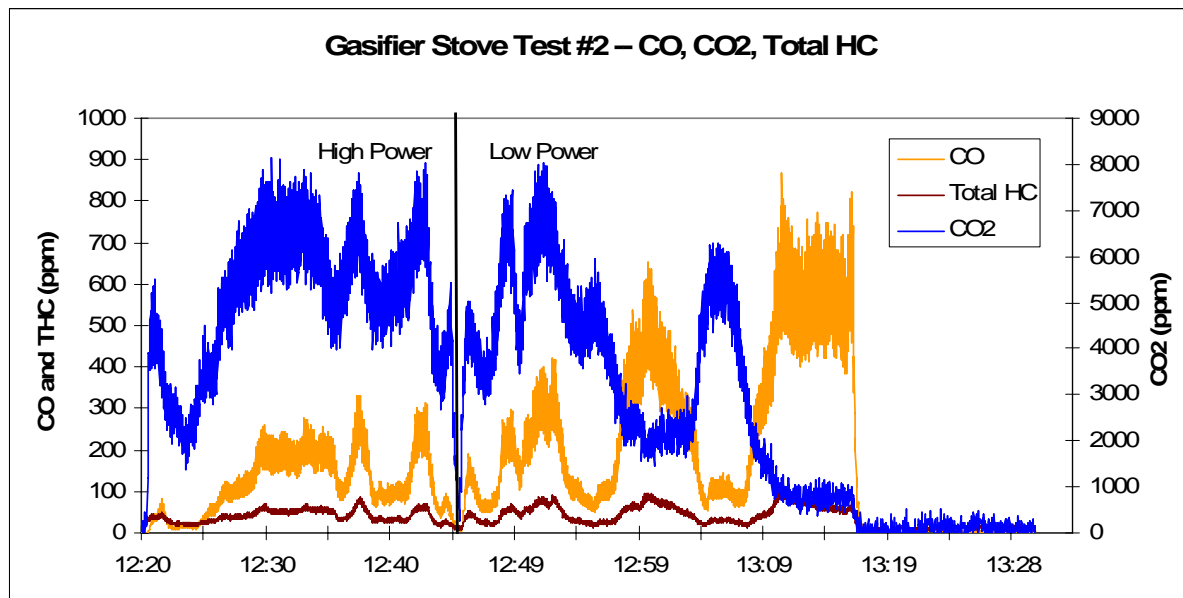

The gasifier has an interesting emissions profile. The firepower as indicated by CO<sub>2</sub> emissions, is higher at the beginning of the test. As the bed of fuel burns and becomes charcoal, CO and HC emissions increase. The hydrocarbon emissions are higher than that of the previous three stoves, and rise and fall in conjunction with CO.

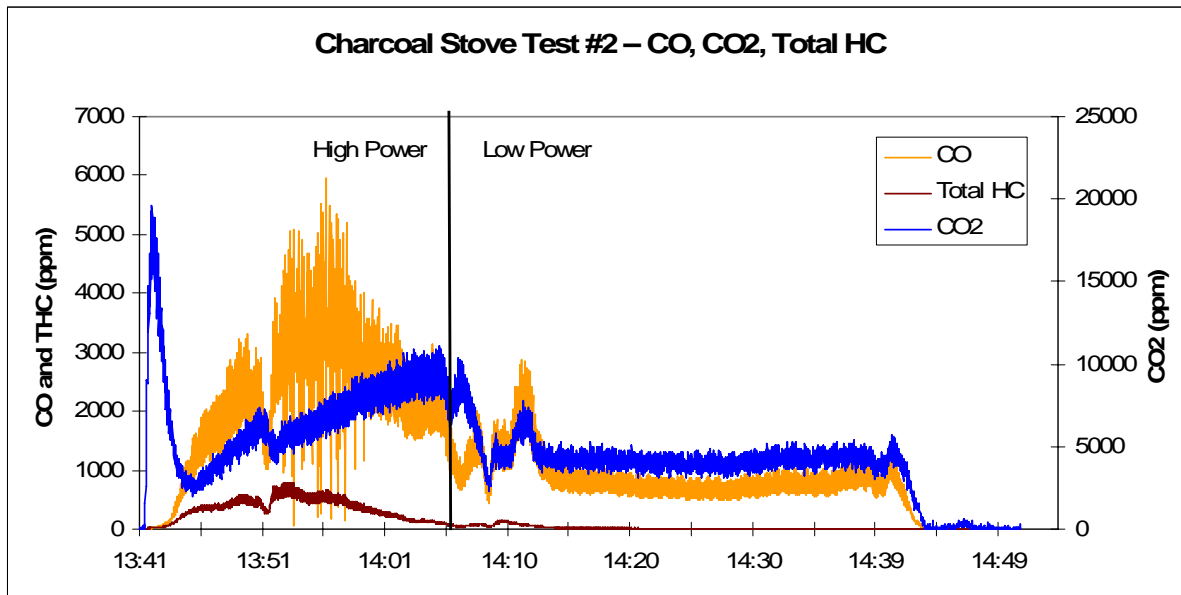

The slow startup time of the charcoal is shown by the gradually increasing levels of CO<sub>2</sub>. At high power, CO emissions are as high as 5000 ppm and the hydrocarbon emissions are up to 1000 ppm. It is expected that the lighter fluid used to start the charcoal burned off within the first 5 minutes; emissions from the combustion of the lighter fluid are seen as a big CO<sub>2</sub> peak at start-up. After that, unusual emissions are not seen, suggesting that the lighter fluid is not a concern in the emissions profile. At the beginning of simmer, the draft door was closed and the emissions stabilize.

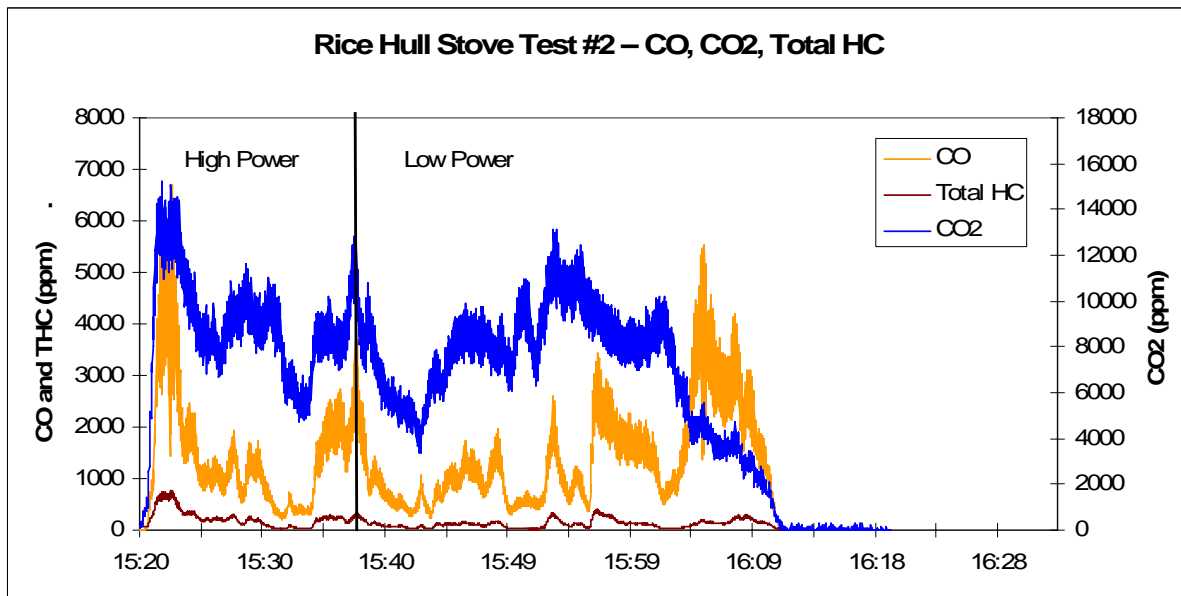

The rice-hull stove is fairly difficult to run consistently, as shown by the varying levels of CO<sub>2</sub>. Emissions of CO and HC can reach high levels that are close to those of burning charcoal. The fire was started using small pieces of kindling soaked in lighter fluid, which may have contributed to the initial peak of hydrocarbons.



## Appendix 2: Variation between Tests

The variation of gas emissions between the three tests was reasonable. The following charts show the variation between the average concentrations of each gas during the high-power test phase of each test.

